

---

# IRIDEON

---

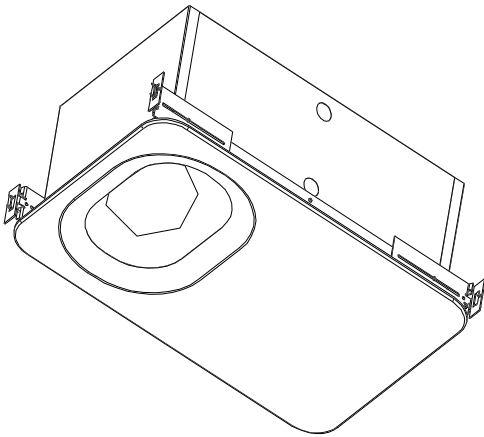

## **Owner's Manual** **AR6™ Recessed Luminaire**

---

### **Reporting Errors and Recommending Improvements**

You can improve this manual. If you find any mistakes, or if you know of a way to improve procedures, please let us know. Send your letter to:

Electronic Theatre Controls, Inc.  
3030 Laura Lane  
Middleton, WI 53562 USA.  
Attn: Service Manager

Our FAX number in Middleton is (608) 836-1736.

---

AR6<sup>TM</sup> Recessed Luminaire

## Patent and Trademark Notice

---

**IRIDEON**<sup>®</sup> is a registered trademark owned by Electronic Theatre Controls, Inc., 3030 Middleton, Wisconsin 53562 USA, and is registered in the United States and other countries.

Composer<sup>™</sup>, AR5<sup>™</sup>, AR6<sup>™</sup>, AR7<sup>™</sup>, AR500<sup>™</sup>, Building With Light<sup>™</sup>, and the Building Design are also trademarks owned by Electronic Theatre Controls, Inc.

**IRIDEON** products and services are protected by one or more of the following patents, and other pending patent applications worldwide:

U.S. Patents No. 5,728,994; 5,367,444; 5,186,536; 5,073,847; 4,779,176; 4,602,321; 4,392,187; U.S.

Design Patents No. D 350,408;

Australia Patents No. 683,695; 667,109; 649,264; 586,095; 576,400; 546,433; Australia Design Reg. No. 128,796; 128,795;

Canada Patents No. 2,070,670; 2,050,375; 1,270,675; 1,259,058; 1,181,795; Canada Design Reg. No. 81,234; 81,233; 76,046;

Europe Patents No. 0 586 049; 0 547 732; 0 474 202; 0 192 882; 0 140 994; 0 060 068;

France Designs Reg. No. 370297 – 3703003;

German Patents No. (DBP) 69208615.3; 69121029; 96314122.0; 3768727; 3279888; 3274291;

German Design Reg. No. M902951.2;

Hong Kong Patents No. 965/1990; 285/1987;

Japan Patents No. 2,059,669; 2,055,324; 1,889,481; 1,770,241; 1,723,825; 1,683,007; 1,533,011;

Japan Design Patents No. 1,002,123; 985,985;

Korea Patent No. 76,310; 42,639;

Korea Design Reg. No. 209,896; 209,895;

Mexico Patent No. 180,148;

Singapore Patents No. 663/90; 134/87;

Spain Patents No. 2.031.748; 2.020.960; 548.328;

Spain Design Reg. No. 137.502; 137.501; 133.573;

Taiwan Patents No. 78,726; 66,975; 65,380; 28,275;

U.K. Design Reg. No. 2056387; 2056386.

---

©1999 Electronic Theatre Control, Inc.. All Rights Reserved.

Information contained in this manual is disclosed in confidence and may not be duplicated by anyone without expressed written permission from Irideon Inc. The purpose of this manual is to provide detailed information relative to the installation, operation, and maintenance of the equipment supplied.

The material presented herein is for information purposes only and subject to change without notice. ETC, Inc. assumes no responsibility for any errors or omissions which may appear in this manual.

## Safety Notice

The following paragraphs contain information pertaining to protection against electrical shock, fire, exposure to excessive UV radiation, and injury to persons.

It is important to read all instructions before mounting and operating IRIDEON® components.

### **WARNING: INSTRUCTIONS FOR PROTECTION AGAINST FIRE**

1. IRIDEON luminaires have been designed for use with specific lamp types. Installing another type of lamp may be hazardous and will void warranty.
2. AR5 luminaires use Phillips DL35 or Osram HTIS35/12 35 watt HID arc lamps. AR6 and AR7 incandescent luminaires use Osram 54052 100 watt tungsten lamps. AR6 and AR7 arc luminaires use G.E. 64356 or Osram 21054 150 watt HID arc lamps. AR500 exterior luminaires use Phillips MSD700W lamps. Lamps from different manufacturers may have different performance characteristics.
3. IRIDEON luminaires may be mounted on any type of surface as long as mounting instructions are followed. (Refer to installation sheet for mounting procedures.)
4. Replace equipment fuses with same type and rating.
5. The AR500 must be kept a minimum of 14 ft. 2 in. (4 meters) from combustible materials. There is no distance requirement for any other IRIDEON luminaire.

### **WARNING: INSTRUCTIONS FOR PROTECTION AGAINST ELECTRICAL SHOCK**

1. Do not install this equipment with power applied. Ensure incoming power is disconnected prior to installation or maintenance of this equipment.
2. This equipment is available in 100 to 120 VAC and 200 to 277 VAC versions. To avoid damage to equipment, do not connect low voltage version to high voltage source or high voltage version to low voltage source.
3. IRIDEON interior architectural luminaires are designed for dry locations only. Exposure to rain or moisture may damage luminaires.
4. Disconnect power before servicing.
5. Servicing, above and beyond those procedures included in the installation and owner's manuals must be performed by qualified personnel only.
6. IRIDEON components are designated as class 1 equipment. Connection to mains power must be done using a three-wire method; line, neutral, and ground. Each component must also be individually grounded.

### **WARNING: INSTRUCTIONS FOR PROTECTION AGAINST EXCESSIVE EXPOSURE TO UV RADIATION**

1. Some IRIDEON luminaires use an HID type lamp that produces UV radiation. Do not look directly at lamp.
2. It is hazardous to operate IRIDEON luminaires with a damaged or missing lens or shield. Lenses or shields must be replaced if they are missing or damaged.

### **WARNING: INSTRUCTIONS FOR PROTECTION AGAINST INJURY TO PERSONS**

1. Luminaire contains hot lamp. Disconnect power and allow lamp to cool before replacing.
2. Wear eye protection when relamping.

# IRIDEON® AR6™ Recessed Luminaire Owner's Manual

## Revision History

<u>Page Number</u>	<u>Revision</u>
--------------------	-----------------

Title Page thru xiv	0
---------------------	---

1 thru 50	0
-----------	---

<u>Version</u>	<u>Date</u>
----------------	-------------

Basic	25 Jun 98
-------	-----------

# Contents

## Introduction

### Chapter 1. Description

<b>Basic Features and Capabilities.....</b>	<b>3</b>
Equipment Description .....	3
Focus .....	4
Color .....	5
Pattern Projection (Spot luminaire only) .....	5
Beam Control .....	6
Timing.....	7
<b>System Configurations.....</b>	<b>9</b>
Overview .....	9
PC only Control System.....	9
MCP Control System .....	10
DMX Interpreter Control System.....	11

### Chapter 2. Installation and Operation

<b>Site Preparation .....</b>	<b>15</b>
Location .....	15
<b>Input Power and Control Cabling.....</b>	<b>17</b>
AC Power Input .....	17
Data Wiring.....	18
Termination Resistor.....	18
<b>Luminaire Installation Procedure.....</b>	<b>19</b>
Unpacking .....	19
Mounting.....	19
Rough-In Installation .....	19
Final Installation .....	21
<b>Luminaire Address .....</b>	<b>23</b>
Setting The Address.....	23
<b>Power Up.....</b>	<b>25</b>
Auto Calibration.....	25

## Chapter 3. Maintenance

<b>Test .....</b>	<b>29</b>
Self Test .....	29
System Test .....	30
<b>Trouble shooting .....</b>	<b>31</b>
General Comments.....	31
Fault Isolation Chart.....	31
<b>Remove and Replace.....</b>	<b>35</b>
Luminaire Trim Cover Removal and Replacement .....	37
Optical Assembly Lowering and Removal .....	38
Lamp Removal and Replacement .....	40
Effects Wheel Removal and Replacement.....	43
Lens Removal and Replacement.....	46

## Limited Warranty

Electronic Theatre Controls, Inc. warrants to Purchaser that for a period of (12) months from date of installation, but not more than (18) months from date of shipment, the Products shall be free from defects in materials and workmanship under normal use and service. Warranty is limited to (60) days from shipment for sample Products or Products used for rental. Electronic Theatre Controls, Inc.'s sole responsibility under this warranty shall be to repair or replace, at Electronic Theatre Controls, Inc.'s option, any nonconsumable part which is defective, malfunctions, or otherwise fails to perform its intended function, when used in a manner consistent with its intended function, provided that customer obtains return authorization in advance from Electronic Theatre Controls, Inc. and ships prepaid any part of the products to be repaired or replaced under the Limited Warranty to Electronic Theatre Controls, Inc. or, at Electronic Theatre Controls, Inc.'s option, to its authorized repair center, within the Limited Warranty period. Irideon, Inc. shall not assume any responsibility for any labor expended or materials used to repair any equipment without Electronic Theatre Controls, Inc.'s prior written authorization. Electronic Theatre Controls, Inc.'s sole obligations and Purchaser's sole remedy for any Product that is defective, malfunctions, or otherwise fails to perform its intended function when used in a manner consistent with its intended function pursuant to the Limited Warranty is repair and/or replacement of the Product. Electronic Theatre Controls, Inc. is not responsible for damage to its products through improper installation, maintenance, use, or attempts to operate product above its rated capacity or voltage, intentionally or otherwise, or for unauthorized repairs.

## **COPYRIGHT**

This manual is protected by copyright; Copyright ©, 1996, 1997, 1998, 1999 Electronic Theatre Controls, Incorporated. All rights reserved. No portion of this manual may be reproduced by any process or technique, without the written permission of ETC, Incorporated.

## **SOFTWARE LICENSE AGREEMENT**

By opening the package containing the Composer™ diskettes and using the Composer program, the purchaser agrees that the program remains the exclusive property of Electronic Theatre Controls and that a personal, non-exclusive license is granted to the purchaser of the equipment to use the program for the operation of the purchased equipment and for no other purpose. A copy of the program may be made for backup purposes. The program may not be reverse engineered, decompiled or disassembled. The creation of derivative works from the program without the written consent of Electronic Theatre Controls is prohibited. Upon the resale of the equipment only the rights granted herein shall be transferred to the purchaser. If you have any questions concerning this agreement, please contact Electronic Theatre Controls at the address indicated below.

If you do not agree to the terms of this agreement, do not open the diskette package. Promptly return it unopened to the place where you obtained it.

Electronic Theatre Controls, Incorporated  
3030 Laura Lane  
Middleton, WI 53562  
U.S.A.

Irideon® and Composer™ are trademarks of Electronic Theatre Controls, Inc. Irideon® is registered in the United States and other countries.



# Introduction

---

## Forward

This owner's manual is confidential property of Electronic Theatre Controls, Inc. All information contained herein is the sole and exclusive property of Irideon, Inc. and may not be used, disclosed, or reproduced in any manner without the prior written consent of Electronic Theatre Controls, Inc.

---

## About This manual

This manual describes specific information regarding description, installation and maintenance of the IRIDEON AR6 Recessed Luminaire. It provides installation, test, fault isolation, and repair procedures for the purpose of general service and repair of the luminaire. The manual is intended for use by owners, installers, and users of the luminaire. The following equipment items are covered in this manual:

- IRIDEON AR6 Recessed Luminaire
- 

## Scope

This manual covers detailed steps for installation of the IRIDEON AR6 luminaire as well as general information for the owner. Instructions for the removing and installing of user replaceable items are also located in this manual. For detailed user instructions of the luminaires within a complete lighting system, refer to the Composer control system owner's manual and PC Software User's Guide.

## Related Documents

In addition to this owner's manual, the following documents are related to the Electronic Theatre Controls, Inc. product line:

### **Irideon, Inc. Applications Guide**

The *Irideon Application Guide* (ETC part number 7090M1009) provides useful guidelines and worksheets to help you understand the capabilities of automated lighting and plan your installation. In addition to specification and installation overviews, the document provides numerous ideas, example installations, and rules of thumb that help you make the most of your lighting system.

### **AR5 Wash Luminaire Owner's Manual**

The *AR5 Wash Luminaire Owner's Manual* (ETC part number 7092M1003) provides a detailed reference on the AR5 luminaire. Fully illustrated, the manual gives step-by-step procedures for site preparation, physical mounting, address configuration, power and control cabling, testing and troubleshooting, and field maintenance procedures (including bulb replacement).

### **AR500 Exterior Wash Luminaire Owner's Manual**

The *AR500 Wash Luminaire Owner's Manual* (ETC part number 7091M1005) provides a detailed reference on the AR500 luminaire. Fully illustrated, the manual gives step-by-step procedures for site preparation, physical mounting, address configuration, power and control cabling, testing and troubleshooting, and field maintenance procedures (including bulb replacement).

### **Composer Control System Owner's Manual**

The *Composer Control System Owner's Manual* (ETC part number 7090M1003) provides a detailed reference on the Composer Control System including Master Control Processor, Expander Module, DMX Interpreter, and Remote Stations. Fully illustrated, the manual gives step-by-step procedures for site preparation, physical mounting, address configuration, power and control cabling, testing and troubleshooting, and field maintenance procedures.

### **Composer PC Software User's Guide**

The *Composer PC Software User's Guide* (ETC part number 7090M1008) provides detailed operating instructions for the Composer PC Software. The document addresses creating, storing, and playing back presets, sequences, templates, schedules and the calendar.

---

## Technical Assistance

### **Electronic Theatre Controls, Inc. Corporate Headquarters**

Electronic Theatre Controls, Incorporated  
3030 Laura Lane  
Middleton, WI 53562

Toll Free: **800.688.4116**  
Voice: **608.831.4116**  
Fax: **608.836.1736**

---

### **Technical and Sales Support**

There are several avenues of support as you plan, purchase, install, and program your lighting system.

### **Electronic Theatre Controls, Inc. Sales Department**

ETC, Inc. sales hours are: 9:00 AM to 6:00 PM Central Time.

Toll Free: **800.215.1823**  
Voice: **608.831.4116**  
Fax: **608.836.1736**  
Internet: **<http://www.etconnect.com>**

### **Your Dealer**

Irideon, Inc. also has a network of authorized dealers. Please call the Irideon, Inc. Sales Department for information about contacting an authorized dealer in your area. Your authorized dealer has been thoroughly trained and equipped to assist you with your automated lighting needs. Contact your dealer first if you have any technical questions. For your convenience, write the name, address, and phone number of your dealer here:

Name: \_\_\_\_\_

Address: \_\_\_\_\_

City: \_\_\_\_\_ State: \_\_\_\_\_ Zip: \_\_\_\_\_

Phone: \_\_\_\_\_ Fax: \_\_\_\_\_

## E-Mail

Ask questions and receive detailed answers from the Technical Support Department. Just send e-mail to the address listed below. You will receive a reply by e-mail.

**Service@etcconnect.com**

## Fax

You can fax questions or comments to Irideon, Inc. Just send a fax to the number listed below. You will receive a reply by fax.

**608.836.1736**

## Telephone

Irideon, Inc. technical support hours are: 9:00 AM to 6:00 PM Central Time. If you call after hours, you may leave voice mail. The voice mail activates a pager, so please indicate clearly if your problem is an emergency. Irideon, Inc. cannot guarantee a response outside of working hours, but emergency calls can generally be handled within a reasonable time.

Toll Free: **800.688.4116**

Direct: **608.831.4116**

When you call, please be at your computer, have your documentation in hand, and be prepared to provide the following information for the components you are using:

- Product serial number used for registration.
- Product version number of the Composer PC software, found by choosing **About** from the **Help** menu in the Composer application.
- The type of computer you are using (including processor type, speed, amount of memory, type of display, etc.).
- Exact wording of any messages that appear on your screen.
- What you were doing when the problem occurred.
- How you tried to solve the problem.

---

## Maintenance

The IRIDEON AR6 luminaire has been designed to be maintenance free. In the event problems do occur, please contact your local ETC distributor or call ETC Technical Support. This manual contains a troubleshooting guide to aid in the identification of failures discovered during initial installation or daily use and for replacement of user replaceable subassemblies.

---

# Manual Organization

---

## Overview

This manual is divided into three chapters:

Chapter 1 contains a description of the AR6 recessed luminaire, including functional descriptions, controls and indicators, major components, internal diagrams, and system diagrams.

Chapter 2 contains the installation procedure, including how to verify proper luminaire operation.

Chapter 3 contains basic testing, troubleshooting, and removal and replacement procedures for user replaceable subassemblies.

*(This page intentionally blank)*

# **Chapter 1.**

## **Description**

- Basic Features and Capabilities
- System Configurations

*(This page intentionally blank.)*



# Basic Features and Capabilities

## Equipment Description

The AR6™ Recessed Luminaire is a specialized interior lighting instrument that offers numerous state-of-the-art features such as patented computer control of light, color, and pattern projection.

The AR6 Recessed Luminaire utilizes a moving mirror technology for virtually silent light beam movement and offers optional features such as color and pattern selection as well as a choice between incandescent or arc lamp source. Additionally, the luminaire offers optional beam control features. The spot version is available with a narrow field-of-view or medium field-of-view lens. The wash version is available with interchangeable narrow, medium, or wide field-of-view lenses.

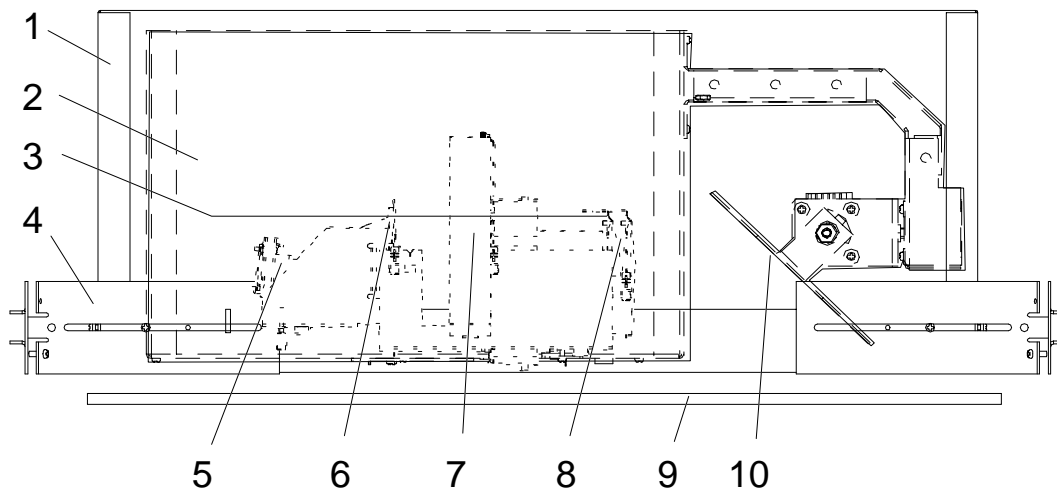

- |                                 |                         |
|---------------------------------|-------------------------|
| 1. Luminaire housing (rough-in) | 6. Reflector            |
| 2. Electrical Assembly          | 7. Color/Pattern wheels |
| 3. Optical Assembly             | 8. Lens group           |
| 4. Mounting Bracket             | 9. Trim cover           |
| 5. Lamp                         | 10. Mirror              |

The IRIDEON™ family of architectural luminaires is controlled by the IRIDEON Composer™ control system.

The luminaire is programmable from a personal computer (PC) and controlled by either a PC; Master Control Processor with or without Expander and/or remote stations; or a DMX Interpreter. The luminaires receive data supplied over a single cable to control not only color, image, and direction, but intensity and transition times between lighting effects.

The spot luminaire is capable of performing five functions: *focus*, *color*, *pattern projection*, *beam* and *timing*. The wash version can perform up to four functions: *focus*, *color*, *beam* and *timing*. A brief description of these functions follows:

---

## Focus

The *focus* function is the luminaire's ability to move the projected light beam in a horizontal (pan) or vertical (tilt) plane. This is accomplished by shining a fixed position light source at a mirror to create a reflection. The mirror is then moved via pan and tilt axis motors to shift the reflected beam of light across a wide arc range.

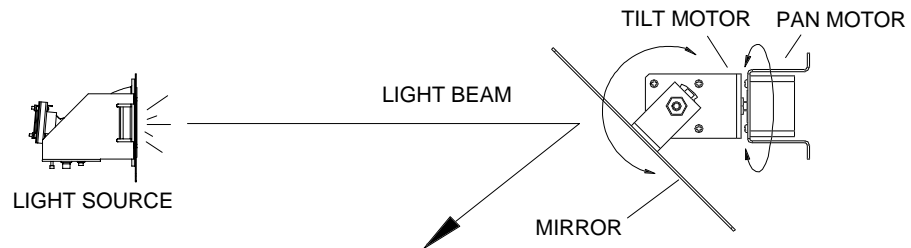

In the AR6 recessed luminaire, pan and tilt *focus* can be achieved manually or via optional motor control.

Manual capability is intended for those users who intend their light to be focused on a single point for extended periods of time but desire full control over color and, in the case of the spot luminaire, pattern projection.

Motorized *focus* provides the user expanded capability in lighting design. Motorized *focus* can be achieved real time at the control station or stored in the preset and activated when the command is executed.

The on-board processor controls individual pan and tilt motors (when selected as an option) that direct the moving mirror to the desired positions within the transition time specified by the preset or real time control. Pan range is 110°. Tilt range is 80°.

## Color

The *color* function controls the color changing mechanism, also known as a color wheel. When one color filter from the wheel is positioned in the light path, the beam of light is filtered to allow a specific light wavelength range to pass through and the desired light color is produced. A motor is attached to the color wheel which rotates its filters into and out of the light path, as directed by the on-board microprocessor. Each color wheel provides for 8 colors plus an open position for unfiltered white light. A set of factory selected saturated colors are available on one color wheel while a second optional color wheel features pastel colors.

THE COLOR WHEEL IS MOUNTED  
OFFSET FROM THE LIGHT BEAM.

THE WHEEL IS ROTATED  
TO PLACE THE DESIRED FILTER  
IN THE LIGHT PATH.

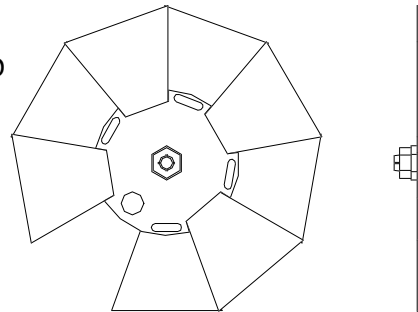

## Pattern Projection (Spot luminaire only)

A pattern wheel is an available option with the spot luminaire. The *pattern* function controls the pattern wheel. Patterns, such as stars, circles, or even company logos, are etched into one of eight frames on a single wheel of coated glass. When a selected pattern from the wheel is positioned (via motor control) in the light path, the coating blocks a portion of the light beam allowing the unetched area to project the pattern on the floor, ceiling, or wall. The pattern wheel working in conjunction with the color wheel provides the opportunity to produce dazzling effects. A set of predefined patterns have been selected for inclusion in this order option. Custom patterns are available through special order.

THE PATTERN WHEEL IS MOUNTED  
OFFSET FROM THE LIGHT BEAM.

THE WHEEL IS ROTATED  
TO PLACE THE DESIRED PATTERN  
IN THE LIGHT PATH.

(ACTUAL PATTERNS MAY BE  
DIFFERENT FROM THOSE SHOWN)

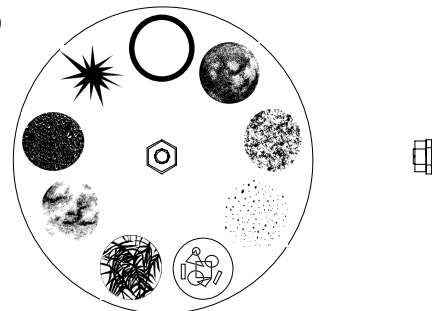

## **Beam Control**

The *beam* function controls the column of light exiting the lens of the luminaire. This column of light is made up of thousands of individual light rays. The outer part of this column is the beam edge.

In the case of the spot luminaire, manual or optional motorized lens control of beam edge is provided to allow the user to choose between a soft or well defined edge or pattern. The spot luminaire may be ordered with either a narrow field-of-view lens set or a medium field-of-view lens set. To change the size of the beam, additional lens sets may be ordered to convert between narrow and medium field of view.

The wash luminaire spreads the beam and eliminates beam edge. The wash luminaire may be ordered as narrow, medium, or wide field-of-view. Additional lens kits are available to convert from ordered beam size to either of the remaining two beam sizes.

---

## Timing

The *timing* function controls the time required to execute a cue. There are two types of *timing*: *Transition* time and *Delay* time.

*Transition* time is the time allowed for a function to complete its operation. For example: One preset may position a beam of light to shine on a wall and the next preset may require the beam to pan over to illuminate a speaker's podium. The time allowed for the beam to move from the wall to the podium is the *transition* time. *Transition* times can be individually set for each of the other functions (*intensity, focus, color, beam*). *Timing* can be used to synchronize the motions of several luminaires so that beams all arrive at their new focus, color, and beam at the same time even though they each may have to pan and tilt through different distances.

*Delay* time is a wait state representing the interval between the time the preset is executed and the time the designated functions begin their transitions. A single delay time can be assigned to one or more functions.

For example: It may be desirable for one or more luminaires washing the walls of a dining room with soft blue light to move their beams slowly to a speaker's podium and then to go white upon arrival drawing obvious attention to the speaker. In this instance the lighting designer might choose to set the transition time of the focus to 20 seconds and the transition time of the color to 0 seconds. This would allow the luminaires to make a gradual movement toward the podium with a near instantaneous change from blue to white. To prevent the light from changing from blue to white at the beginning of the pan movement, the designer would specify that a delay time of 19 or 20 seconds be provided and affect only the color.

The features are defined and combined using a PC and result in a specific look known as a "lighting state" or preset.

*(This page intentionally blank.)*

---

# System Configurations

---

## Overview

The IRIDEON architectural interior lighting system consists of IRIDEON interior luminaires and the Composer control system. The control system may be supported by: **1.** PC only; **2.** PC, Master Control Processor with or without remote recall stations; or **3.** DMX Interpreter with DMX512 input.

## MCP Control System

A control system featuring a Master Control Processor is able to support 62 IRIDEON luminaires utilizing the IRIDEON data protocol for luminaire operation. Optional remote stations provide the added flexibility of 2 and 8 button recall stations, programming stations, key switch security stations, and 8 event closure/join stations.

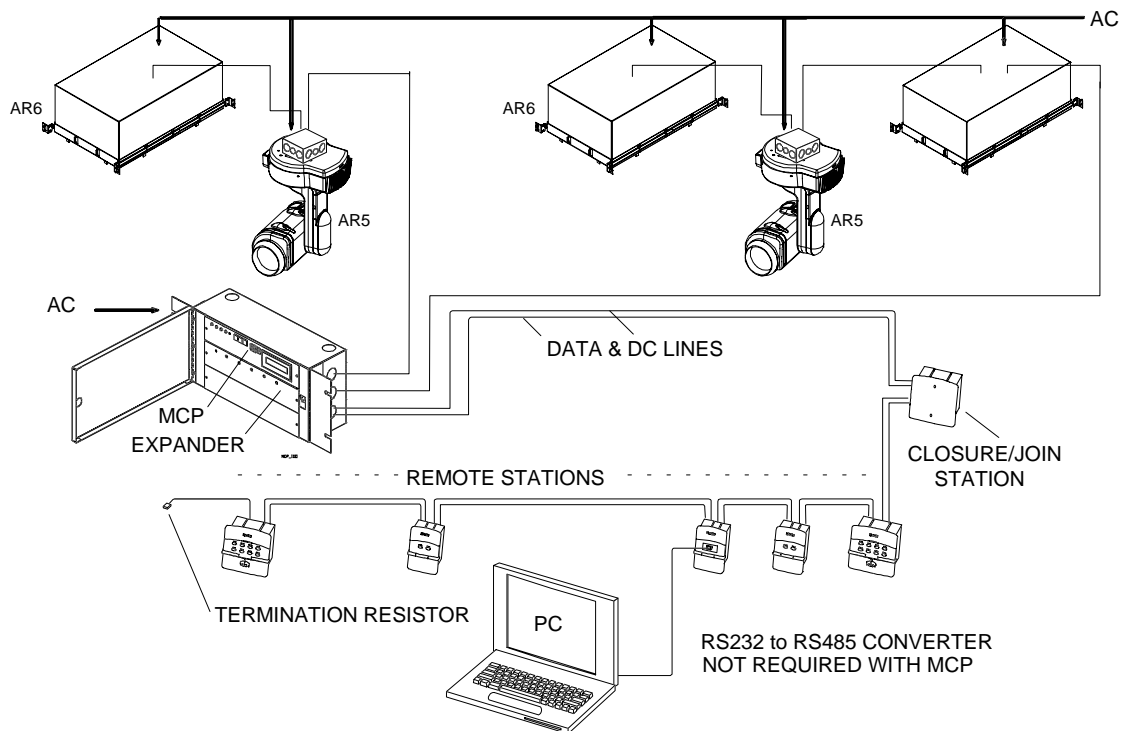



## DMX Interpreter Control System

The DMX Interpreter receives DMX512 data and converts it to the IRIDEON data protocol for luminaire operation. Up to 31 IRIDEON luminaires are supported on each of 2 data runs for a total of 62 luminaires.

Refer to the IRIDEON Composer Owner's manual for in depth discussion of system configurations.

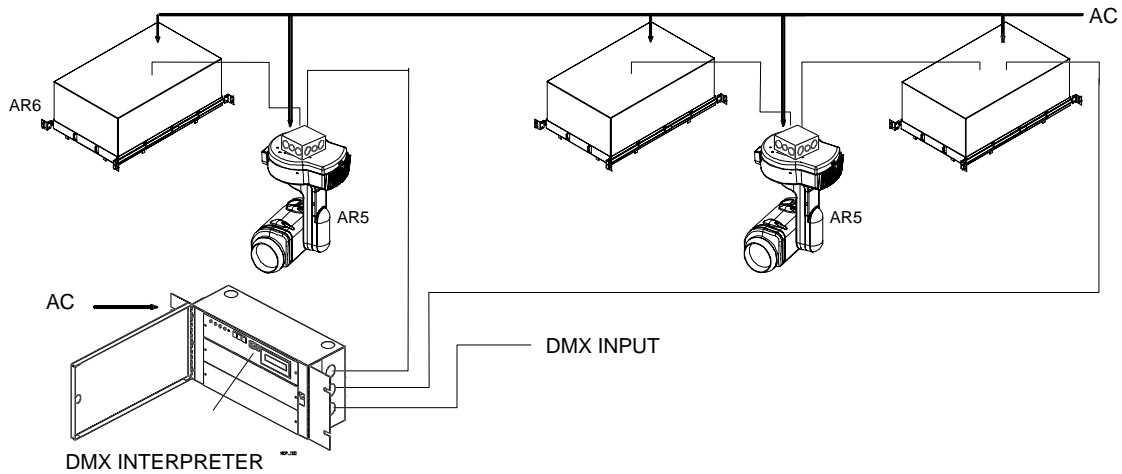

*(This page intentionally blank.)*

## **Chapter 2.**

# **Installation**

- Site Preparation
- Input Power and Control Cabling
- Luminaire Installation Procedure
- Fixture Address
- Power Up

*(This page intentionally blank.)*

# Site Preparation

## Location

The IRIDEON AR6 recessed luminaire may be mounted along a horizontal (ceiling), vertical (wall), or inclined plane. The installation location must provide an indoor non-condensing, low humidity environment. The luminaire should be securely mounted to a structure capable of supporting 30 lbs (13.6 kg).

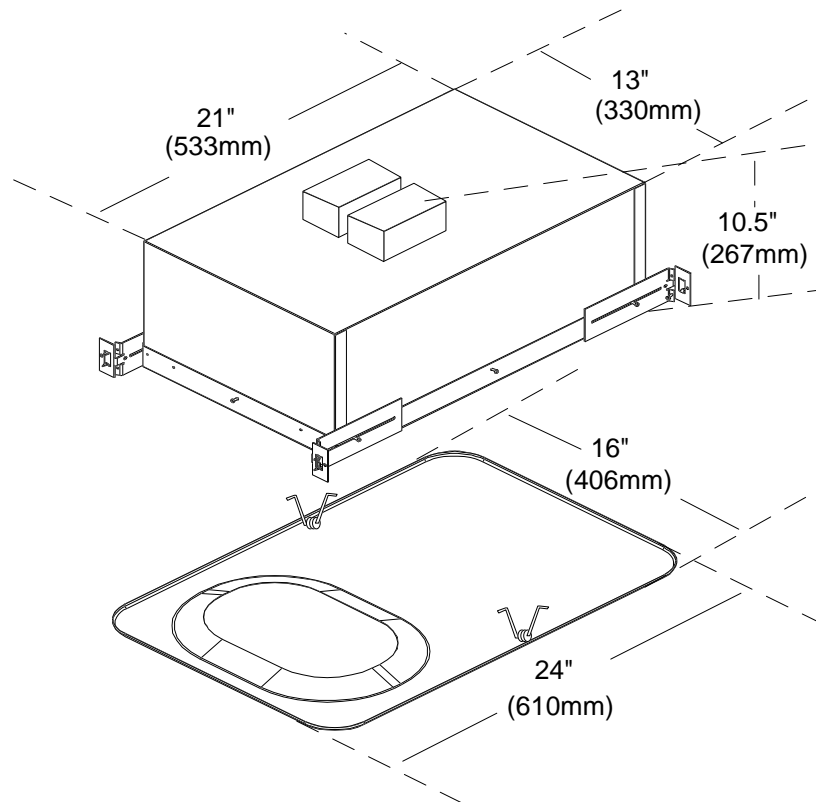

Enclosure hole size is 14" x 22" (+/- 1")  
356mm x 559mm (+/- 25mm)

*(This page intentionally blank.)*

# Input Power and Control Cabling

## AC Power Input

**Note:** The installation contractor is responsible for compliance with local electrical codes.

**Note:** Data and AC power must be routed through separate conduit.

**Input Rating:** 100 - 277VAC 50/60Hz 3A max.

AR6 luminaire power requirements at sample voltages are listed below.

115V @ 3A

208 - 277V @ 2A

AC wiring may use 18 - 10 AWG service to luminaire housing rough-in box. Connect as follows:

Wire	Connection
BLACK *(BROWN)	AC LINE
WHITE *(BLUE)	AC NEUTRAL
GREEN or bare *(GRN/YEL)	GROUND

- International (Harmonized) Standard

**CAUTION:** Ensure ground wire connected properly prior to applying power.

## Data Wiring

**CAUTION:** It is not recommended that control and AC power cabling be installed without conduit.

### Control

Numerous Category 5 cables (24AWG solid conductor, shielded, twisted pairs) have been evaluated and approved for use with the Composer control system. Recommended data cables are as follows:

- Belden 1589A
- Belden 1584A
- Alpha 9504CS
- Manhattan/CDT M19094

## Termination Resistor

The AR6 recessed luminaire is equipped with an internal termination resistor. The resistor is shipped in a deactivated condition and will need to be activated for the last luminaire in a data run. Locate the luminaire address switch on the back side of the control card. Access is made through a small cutout on the luminaire electrical assembly housing wall. Set switch position 8 to "on". This will activate the termination resistor for that luminaire.

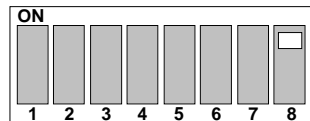
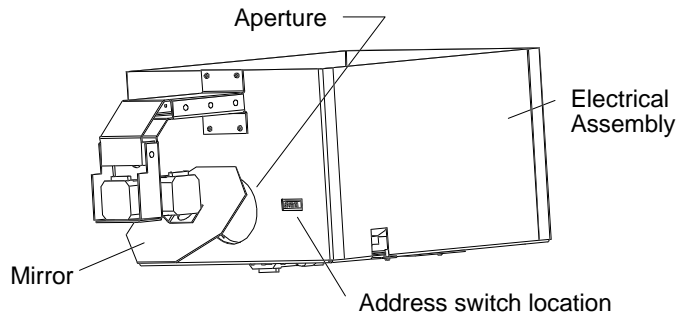

**SWITCH SETTING 8  
ACTIVATES TERMINATION  
RESISTOR WHEN SWITCHED  
TO "ON".**

**ACTIVATE FOR LAST LUMINAIRE IN DATA RUN.**



# Luminaire Installation Procedure

## Unpacking

Remove the luminaire from its packing cartons. Save packing materials in the event luminaire requires future shipment.

## Mounting

**Note:** Luminaires housings should be mounted with consistent orientation (all housing mounted in a north/south or east west orientation as opposed to some north/south and some east/west). This can simplify programming luminaires at a later time.

## Rough-In Installation

The luminaire housing is available for shipping separately, in advance of the luminaire's electrical and optical components, to support electrical "rough-in" requirements. If the luminaire is shipped as a single unit, it will be necessary to remove the electrical assembly from the outer housing for installation.

Enclosure hole size is 14" x 22"  $\pm$ 1" (356mm x 559mm  $\pm$ 25mm).

The luminaire is designed to fit between ceiling rafters or wall studs with 16" (406mm) centers. UL codes require a minimum of 1/2" (12mm) clearance on all sides of framing. Adjustable mounting brackets are provided to accommodate a range of openings up to 24" (610mm). Brackets can be installed on the long or short sides of the housing to aid installation. Maximum bracket reach is 16" x 24" (406mm x 610mm)

For suspended ceiling installations, the adjustable mounting brackets are notched to fit over the ceiling tile support tracks.

For metal framed structures, flatten prongs and use screws to secure.

For wood framed structures, hammer prongs into studs and secure with screw or nail through hole.

Notches set over suspended ceiling tracks. Tighten screws against tracks to secure.

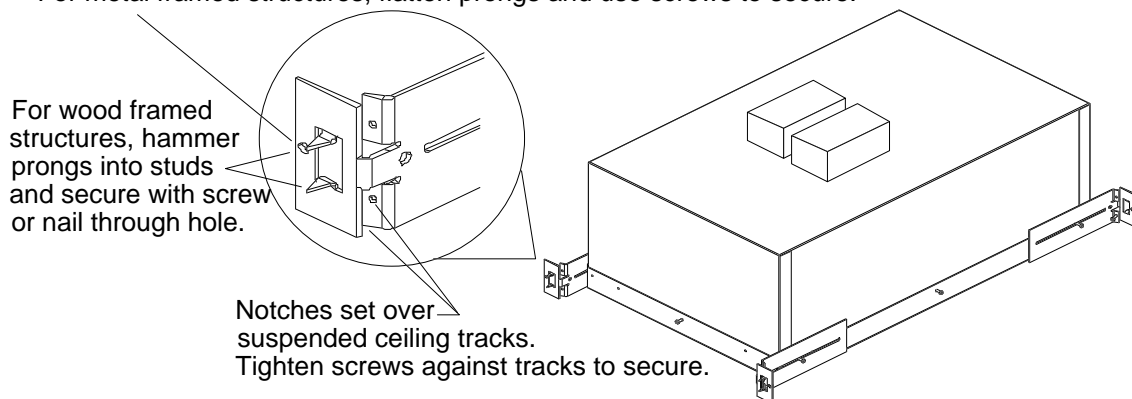

The luminaire housing is furnished with two external junction boxes to allow for separated AC power and data connections as required. AC power and data should be routed through separate flex conduit. AC and Data pigtail cable assemblies are provided in each junction box. Data is to be connected to source in a daisy-chained method. Wire nuts are acceptable for AC hookup, however terminal strips are recommended for use in data connections.

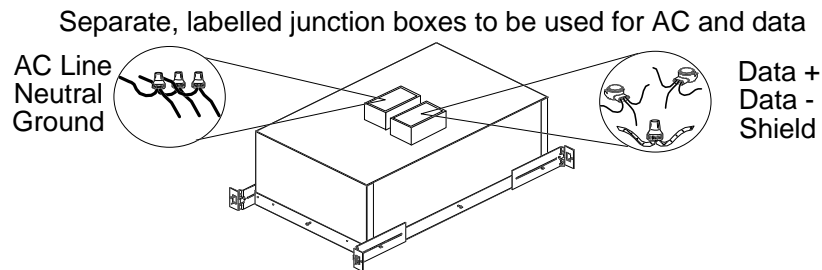

Connect source AC and data to pigtails provided

Color code for data pigtail is:

Wire	Color
Data +	White
Data -	Violet

## Final Installation

For final installation, the luminaire is supplied in two parts. The electrical assembly is shipped with the optical assembly mounted inside. The Trim Cover is the second part and attaches after the electrical assembly has been installed in the rough-in housing. Ballast, power supply, control board, mirror assembly, etc. are attached to the electrical assembly. The Optical assembly contains the lamp, lenses, and effects bulkheads (color wheel, pattern wheel, etc). The Trim Cover is a painted cosmetic cover with an oval aperture for light transmission.

The electrical assembly mounts to the luminaire housing (previously installed during rough-in) by means of tab/slot combinations and screws.

**Note:** It is recommended that luminaires be mounted with consistent orientation (mirror end of all luminaires pointing in same direction) to simplify luminaire programming.

### To install electrical assembly in the luminaire housing:

- Step 1. Determine electrical assembly orientation. Route housing pigtail cable to side shown in illustration below.
- Step 2. Lift electrical assembly to luminaire housing and insert housing tabs into slots on electrical assembly.
- Step 3. Lift mirror end of electrical assembly to align tabs with housing screws. Slide tabs around screws and secure. Secure end of electrical assembly opposite mirror to housing using screws provided.

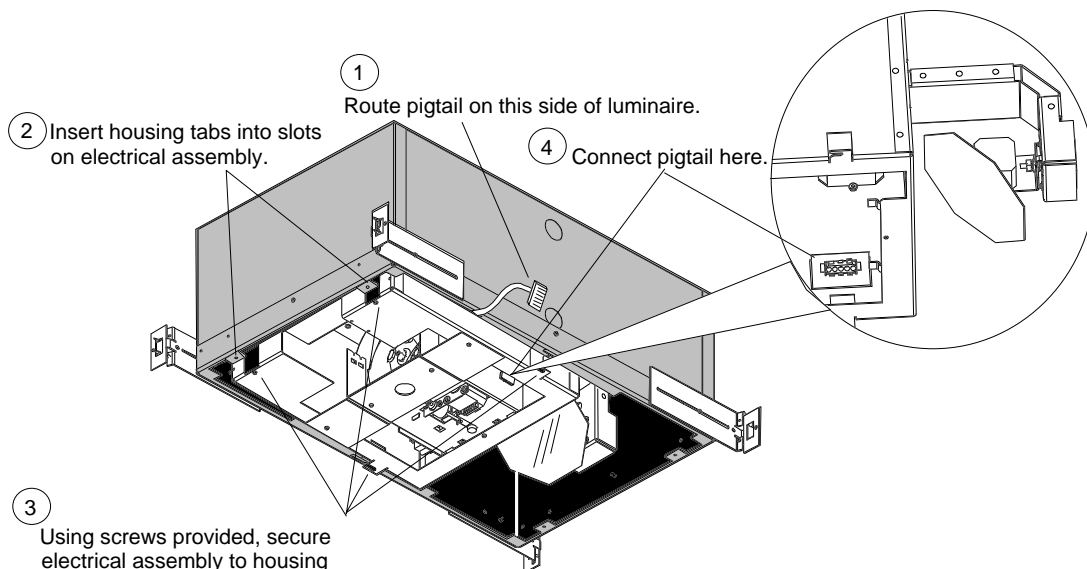

- Step 4. Locate AC and data pigtail cable supplied with housing. Connect cable plug to connector mounted in electrical assembly.

- Step 5. Lower optical assembly and install bulb (if not already in luminaire). Refer to **Removal and Replacement of Lamp** procedure in maintenance section of this manual.

---

# Luminaire Address

---

## Setting The Address

Each luminaire in a data run must be set to a unique address in order to receive the proper data that controls that individual luminaire. Luminaire address selection typically results from the overall plans of the lighting designer. Specific addresses for each fixture should be furnished by that designer.

The luminaire address is set by a single eight position dip switch located on the back side of the main control card. The control card is mounted to the front wall of the luminaire's electrical assembly. The switch may be seen and accessed via a small rectangular cutout on the electrical assembly wall to the right of the aperture hole.

The first six positions of the eight position dip switch represent the luminaire address. The seventh position is dedicated to a self test program, and the eighth position is to activate the termination resistor for the last luminaire in a data run.

### To set the fixture address:

Step 1. Determine the appropriate luminaire address. This information should be supplied by the lighting designer.

---

**Note:** Each luminaire in a data run must have a unique address. The same address may be used by luminaires in different data runs. A data run is considered to be a continuous daisy-chained string of luminaires originating from a single output connector on the MCP, DMXI or personal computer.

---

Step 2. Consult the following table to determine switch settings for each individual luminaire.

Step 3. Using a small screwdriver or similar object, slide the switch tabs to the "on" or "off" positions corresponding to the address settings identified in the table.

---

**Reminder:** The seventh position on the address switch is the self test position. Leave this tab at the factory pre-set position of "off" unless the internal luminaire self test program is desired. Luminaire will not respond to external commands while position 7 is in the "on" position. The eighth position is to activate the termination resistor. Leave this tab at the factory pre-set position of "off" unless the luminaire is the last in a data run.

---

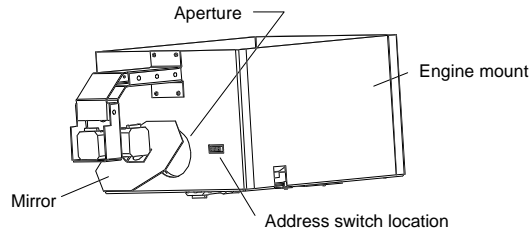

### Fixture Address Switch Settings

Address / Setting	Address / Setting	Address / Setting	Address / Setting
0*	16	32	48
1	17	33	49
2	18	34	50
3	19	35	51
4	20	36	52
5	21	37	53
6	22	38	54
7	23	39	55
8	24	40	56
9	25	41	57
10	26	42	58
11	27	43	59
12	28	44	60
13	29	45	61
14	30	46	62
15	31	47	

\*A setting of all 0's is not a valid luminaire address.

---

# Power Up

---

## Auto Calibration

When power is applied, the luminaire will immediately begin a calibration sequence that steps it through operational movements, then the arc lamp will “strike” or ignite (the incandescent will turn on).

To verify proper calibration sequence, observe the following:

- Pan and tilt motors move to their extreme positions.
- Effects wheels (color and/or pattern) rotate until magnet on wheel is detected by sensor board.
- Mirror rotates to “home” position (mid-rotation of pan and tilt unless reprogrammed by user).
- Wheels rotate to open positions so that light is open white.
- Lamp illuminates.

*(This page intentionally blank.)*



## **Chapter 3.**

# **Maintenance**

- Test
- Trouble shooting
- Remove and Replace

*(This page intentionally blank.)*

# Test

## Self Test

Internal diagnostic self tests are provided with the luminaire to exercise color, pattern and mirror movement.

The luminaire self test is set by a single eight position dip switch located on the back side of the main control card. The control card is mounted to the front wall of the luminaire's electrical assembly. The switch may be seen and accessed via a small rectangular cutout on the electrical assembly wall to the right of the aperture hole.

The first six segments of the eight position dip switch represent the luminaire address. The seventh position is the self test position and the eighth position is to activate the termination resistor for the last luminaire in a data run. Self test continues to cycle until switch is set to "off".

### To initiate self test:

Step 1. Set the seventh position on the fixture address switch to "on".

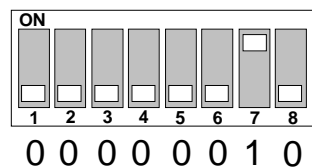
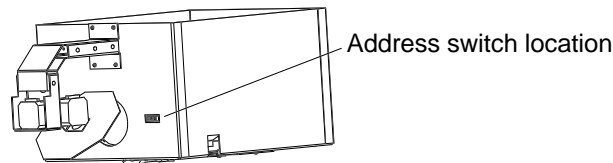

SWITCH SETTINGS FOR  
POSITIONS 1 THROUGH 6  
AND POSITION 8 HAVE NO  
EFFECT ON SELF TEST

Step 2. To verify proper self test operation, observe the following:

- Pan at mid-rotation, Tilt at one extreme rotation limit. One second later tilt moves to opposite extreme in five seconds.
- Effects wheels step in same direction at approximate rate of one second per filter/pattern.
- After 4 seconds, pan moves to one extreme rotation limit, tilt moves to mid rotation. Wheels continue to step for 4 more seconds.
- Effects wheels move at fast rotation in same direction for 5 seconds.
- Effects wheels move at slow rotation for 8 seconds.
- Wheels reverse direction and fast spin for 5 seconds.

## **System Test**

Refer to **Composer** operating system documentation for system testing.

# Trouble shooting

## General Comments

**Note:** If it becomes necessary or desirable to return a subassembly or the luminaire to an authorized service center, a Return Material Authorization (RMA) must be obtained prior to shipment. Items will not be accepted without an RMA number.

AC power is required to strike (or ignite) and maintain illumination of the lamp. AC power is also required by the Low Voltage Power Supply to create +24vdc for developing drive motor and digital circuit voltages.

## Fault Isolation Chart

Assuming that all other system components are working properly and that proper system power has been supplied to the luminaire:

Symptom	Probable Cause	Corrective Action
No Response to Movement Commands and Lamp not Lit.	No AC power to luminaire.	Refer to following pages.
No Response to Movement Commands but Lamp is Lit.	No DC power.	Refer to following pages.
Luminaire responds to movement commands but lamp will not Light.	Lamp striking timed out. Bad Lamp.	Refer to following pages.

## **No Response to Movement Commands and Lamp not Lit.**

Movement is controlled by DC motors. Lamp is lit by AC power. This combination of no movement and unlit lamp indicates no power is going to the luminaire.

Assuming the following:

- Luminaire and control system properly connected to main power source.

- Step 1. Verify circuit breaker is on (Are other items on same circuit working properly?). Turn power off and back on.
- Step 2. Push lightly against mirror. Slight resistance will be observed if power is applied to motors, no resistance will be felt if power is absent from mirror motors.
- Step 3. Locate opening in electronics assembly wall where fixture address switch is accessed. If green LED is flashing, control card and low voltage power supply are functioning properly.

---

## **No Response to Movement Commands but Lamp is Lit.**

Assuming the following:

- Data cables between luminaire and controller properly connected.
- Other luminaires in system properly responding to commands from control system.
- Fixture address switch set to proper address and matching address in control system for that luminaire.

Step 1. Perform luminaire self test. Refer to Self Test procedure in this chapter. If luminaire mirror, color wheel, and pattern wheel fail to move, check power supply for +24VDC.

Step 2. If luminaire responds properly to self test, return luminaire to correct fixture address switch setting and perform Composer control system self test. Refer to Composer Owner's Manual for self test procedure.

## **Luminaire responds to movement commands but lamp will not Light.**

Step 1. **For arc lamps only.** Remove power to luminaire for at least 5 minutes. Restore power and listen for “clicking” sound from luminaire (if sound is present, lamp is trying to strike indicating presence of AC power). If lamp tried to strike but did not ignite, replace lamp.

If “clicking” sound is present but lamp will not ignite, replace lamp.

---

**CAUTION:** Do not touch glass portion of lamp.

---

If no “clicking” sound is present, replace ignitor.



---

## Remove and Replace

---

---

**WARNING:** Potentially hazardous voltages exist. Remove power during maintenance operations.

**WARNING:** Lamp and surrounding area may be extremely hot.

**WARNING:** Breakable glass and metal parts under tension are in use in many of the luminaire assemblies. Eye protection should be worn during maintenance operations.

---

---

This section deals with the removal and installation of user replaceable items and contains the following topics:

- Trim Cover
- Optical Sub-assemblies

Lamp

Effects Wheels

- Lenses

*(This page intentionally blank.)*

---

## Luminaire Trim Cover Removal and Replacement

---

**WARNING:** Remove power to luminaire at main breaker prior to performing maintenance.

---

**Tools:**

none required

- Step 1. Grasp trim cover outer edge or aperture edge and pull 1"-2" (25mm-50mm) straight down.
- Step 2. Squeeze spring retaining clip legs together until clip releases from luminaire housing. Remove trim cover.

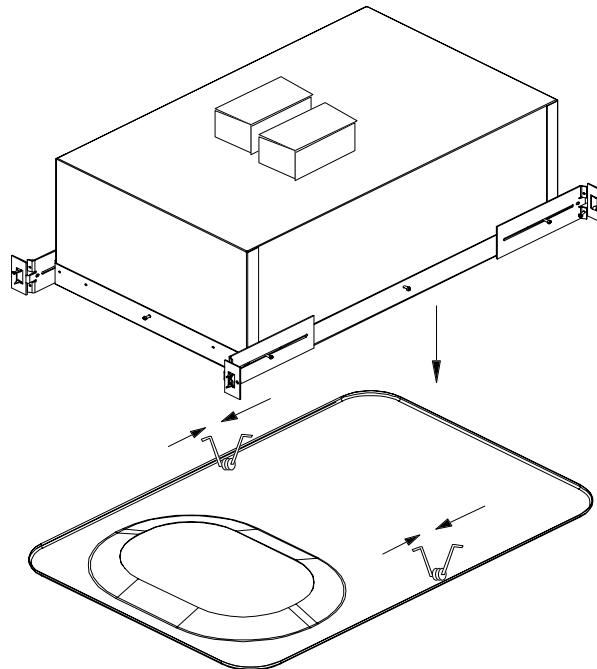

Squeeze spring clip legs together and slide out from housing.

---

## Optical Assembly Lowering and Removal

---

**WARNING:** Remove power to luminaire at main breaker prior to performing maintenance.

**WARNING:** Wear eye protection while performing maintenance.

---

Tools:

Screwdriver, phillips, #2

### To remove the optical assembly from luminaire electrical assembly:

- Step 1. Remove luminaire trim cover. Refer to **Luminaire Trim Cover Removal and Replacement** procedure.
- Step 2. Lower optical assembly.
  - a. Near reflector base, unplug lamp connector.

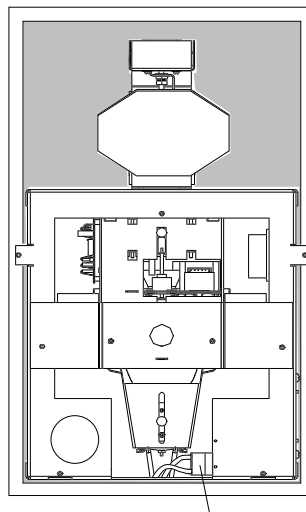

Disconnect lamp power here

- b. At lens end of optical assembly, using phillips screwdriver, loosen screw securing optical assembly to electrical assembly.
- c. At optical assembly cross member, using phillips screwdriver, loosen screw on both sides of cross member while supporting optical assembly with free hand.

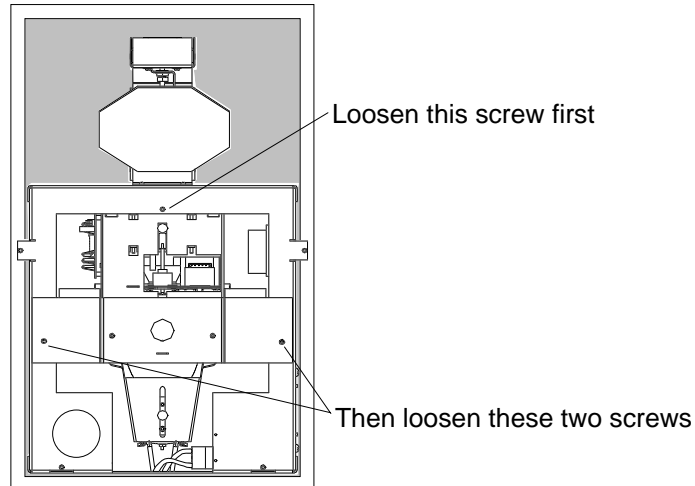

Note: When screws are loosened, optical assembly will be unsupported and swing downward on hooks located at lens end of assembly. Support unit with hands while lowering.

- d. Allow optical assembly to hang from hooks on electrical assembly.

Step 3. Remove optical assembly from mount.

- a. Grasp optical assembly and lift slightly.
- b. Slide optical assembly backward to free from electrical assembly hooks.

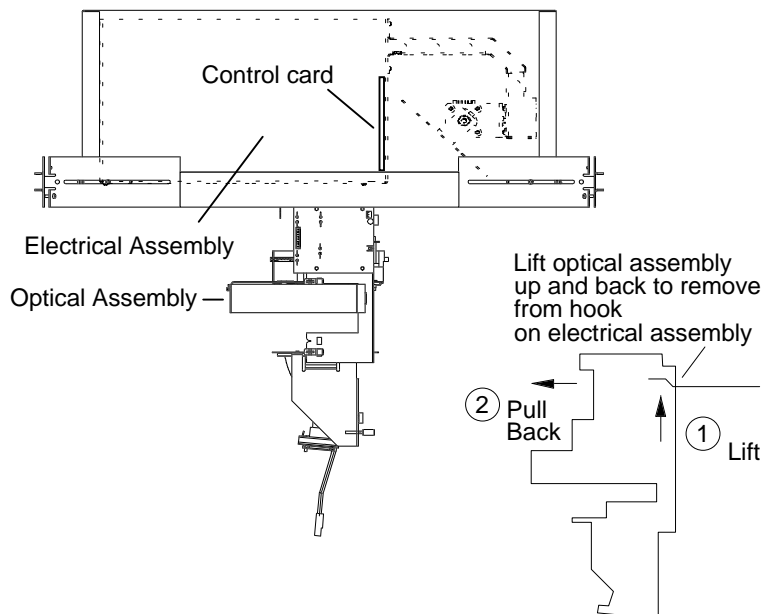

- c. Unplug motor cabling from control card located on front wall of electrical assembly.

---

## Lamp Removal and Replacement

---

**WARNING:** Remove power to luminaire at main breaker prior to performing maintenance.

**WARNING:** If lamp has been illuminated, lamp and surrounding area may be extremely hot. Allow to cool 30 minutes prior to attempting replacement. Perform lamp alignment within 30 minutes of applying power or wear gloves.

---

Tools:

Screwdriver, phillips, #2

### To remove and replace a lamp in the optical assembly:

- Step 1. Remove luminaire trim cover. Refer to **Luminaire Trim Cover Removal and Replacement**.
- Step 2. Lower optical assembly to gain access to lamp. Refer to Steps 1 and 2 of **Optical Assembly Lowering and Removal** procedure.
- Step 3. At rear of reflector assembly, grasp lamp socket side tabs and rotate counter-clockwise approximately 1/4 turn to release from reflector assembly bracket. Pull lamp and socket back and away from reflector.

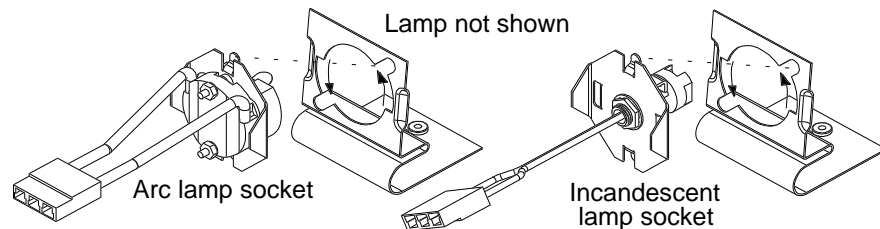

Rotate clockwise to install. Rotate counter-clockwise to remove.

- Step 4. Grasp ceramic base of lamp and remove from socket.
- Step 5. Place new lamp in socket, do not touch glass portion of lamp with fingers.

---

**CAUTION:** Do not touch glass portion of lamp with bare hands. This will leave skin oils, which will damage bulb when it reaches full operating temperature. If glass is accidentally touched, clean with soft cloth and alcohol prior to installation.

---

- Step 6. Align tabs on top and bottom of lamp socket with notches on reflector assembly bracket. Insert tabs and rotate clockwise approximately 1/4 turn.

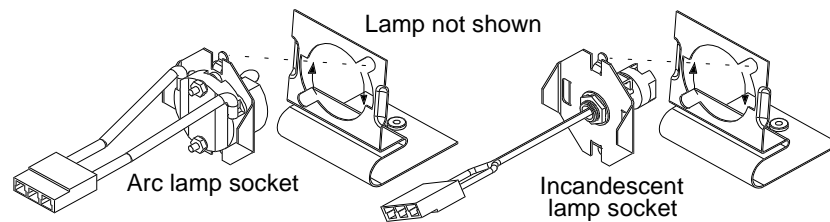

Rotate clockwise to install. Rotate counter-clockwise to remove.

- Step 7. Replace optical assembly in luminaire by performing maintenance procedure **Optical Assembly Lowering and Removal** steps 2 and 3 in reverse order.
- Step 8. Using adjustment knobs on bottom of reflector assembly, align lamp for optimum brightness.
- a. Position mirror so that light shines on flat surface.

**Note:** There are two approaches to adjusting beam brightness. One approach is to position mirror so beam shines on a flat white surface, ideally 10 feet from luminaire. This allows the operator the opportunity to most clearly see the beam image when adjusting brightness. The second approach is to position the beam to shine on the area where it will most often be used in normal operation. This will allow the adjustment to be better tailored to specific applications.

- b. Using larger diameter adjustment knob, loosen and slide lamp mount forward and back until brightest beam image is present.

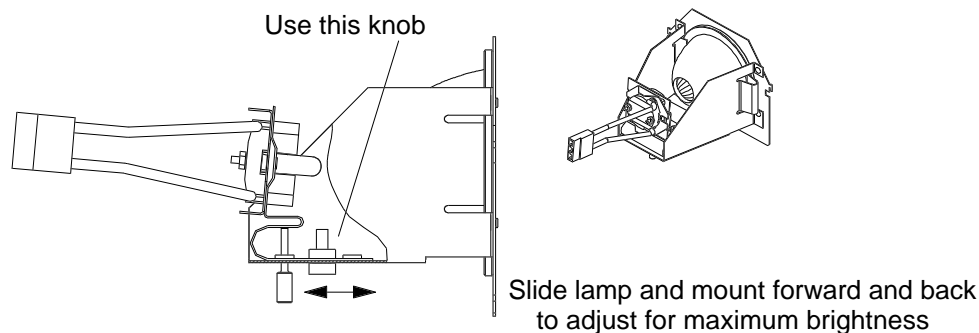

- c. With adjustment knob still loose, move reflector from side-to-side to center beam and maximize brightness. Tighten knob when adjustment is complete.

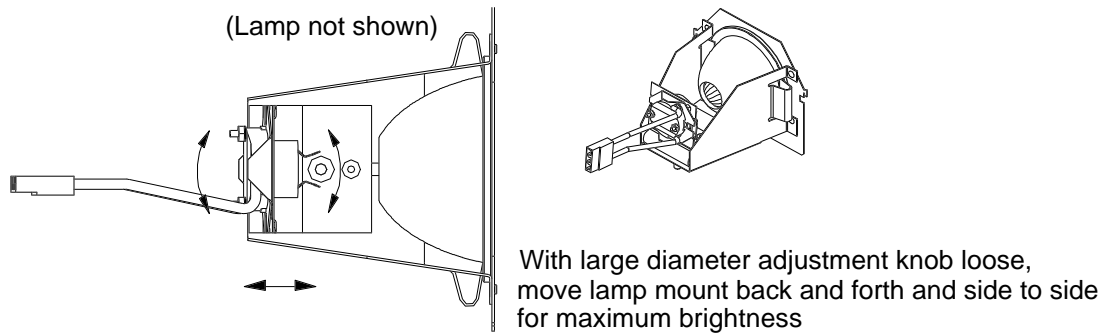

- d. Using thinner adjustment knob, turn clockwise and counter-clockwise to raise and lower lamp mount and center lamp for maximum brightness.

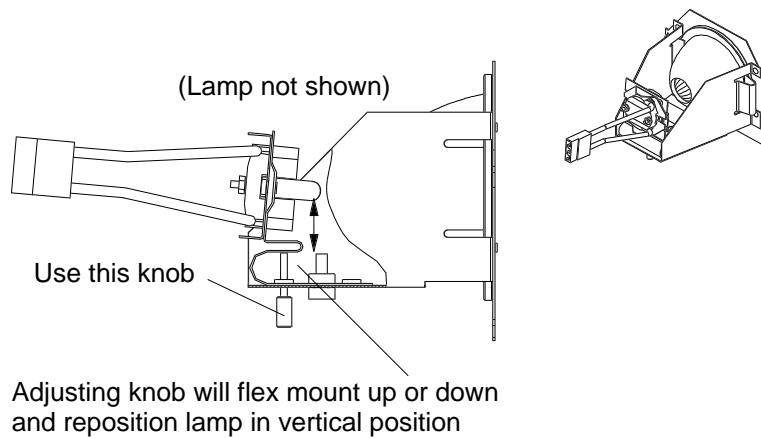



---

## Effects Wheel Removal and Replacement

---

**WARNING:** Remove power to luminaire at main breaker prior to performing maintenance.

**WARNING:** Wear eye protection during maintenance operations.

---

**Note:** If two wheels are installed and the innermost is to be replaced, it will be necessary to first remove the outermost wheel.

---

**Parts:**

Standard Image Wheel	Part Number 7093A2002-1
Saturated Color Wheel	Part Number 7093A2001-1
Pastel Color Wheel	Part Number 7093A2001-2

**Tools:**

2 ea. wrench, 7/16" open end

**To remove and replace effects wheel(s):**

- Step 1. Remove luminaire trim cover. Refer to **Luminaire Trim Cover Removal and Replacement**.
- Step 2. Lower and remove optical assembly to gain access to effects wheel. Refer to Steps 1,2 and 3 of **Lowering and Removal of Optical Assembly** procedure.

**To remove and replace effects wheel(s):**

- Step 1. Remove nuts and lift off protective straps from around effects wheels.

Remove nuts and lift off protective straps from effects wheels

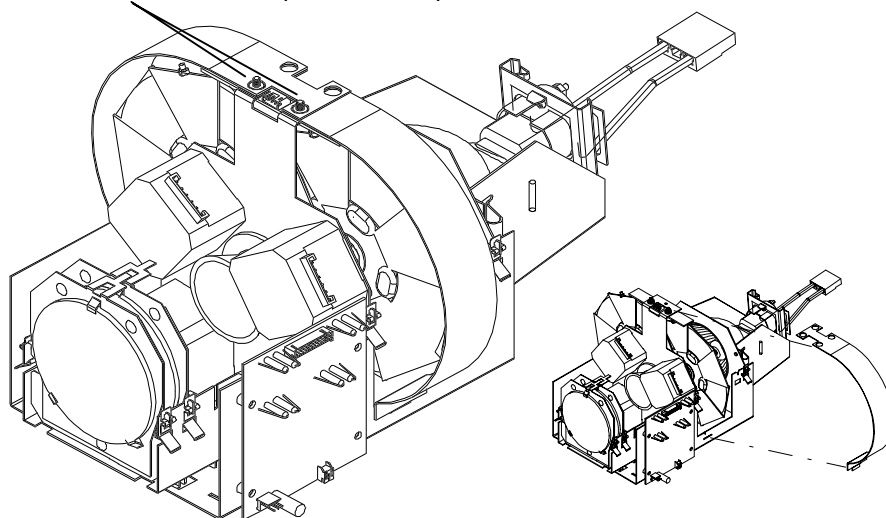

Step 2. At outermost effects wheel, using wrenches, loosen and remove wheel retaining nut. Slide effects wheel off motor shaft. If outermost of two wheels is only wheel to be replaced, proceed to Step 5.

Step 3. At innermost effects wheel, using wrenches, loosen and remove wheel retaining nut. Slide effects wheel off motor shaft.

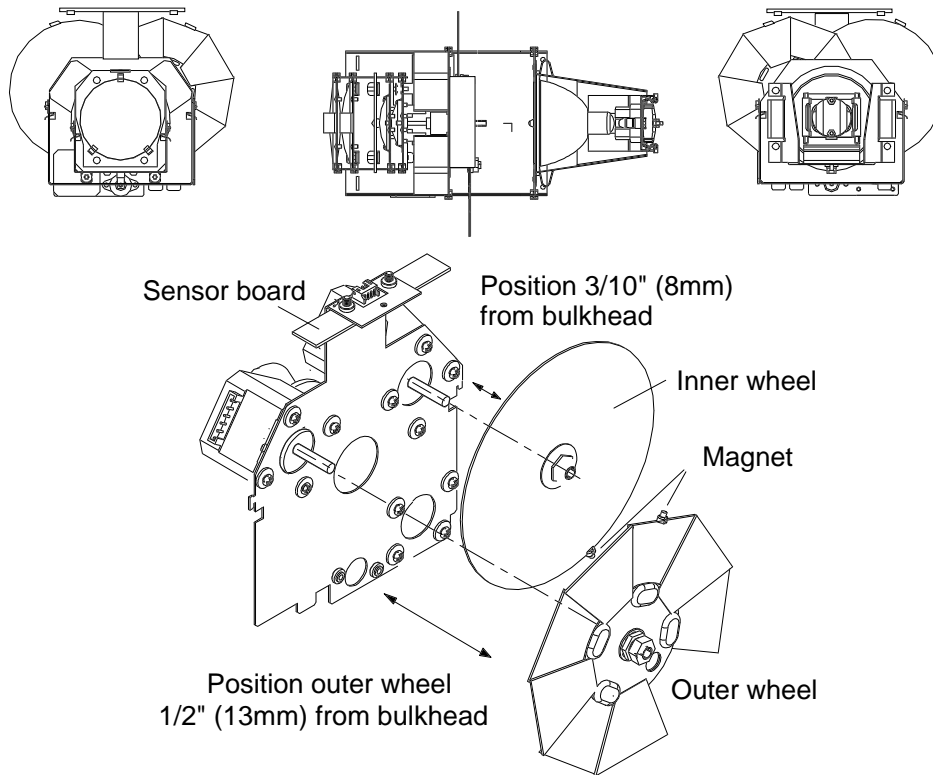

Step 4. Replace innermost effects wheel with nut toward light source. Using slot on side of optical assembly housing, align wheel with slot. This should ensure distance between glass portion of wheel and bulkhead is .300" (7.62mm). Using one 7/16" wrench on collet and one 7/16" wrench on nut, tighten wheel on shaft and ensure effects wheel turns without striking any other parts and is secure on shaft. Magnet, mounted on edge of wheel, must pass directly under sensor on board above wheel.

Step 5. Replace outermost effects wheel with nut toward light source. Using slot on side of optical assembly housing, align wheel with slot. This should ensure distance between glass portion of wheel and bulkhead is .500" (12.7mm). Tighten collet and ensure effects wheel turns without striking any other parts and is secure on shaft. Magnet, mounted on edge of wheel, must pass directly under sensor on board above wheel.

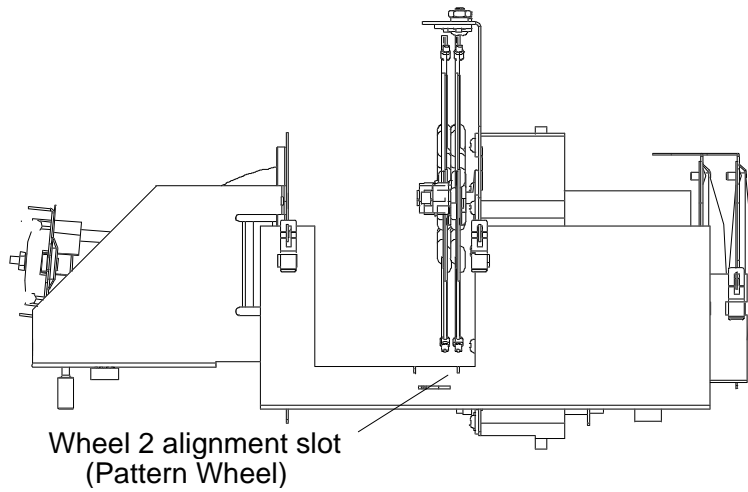
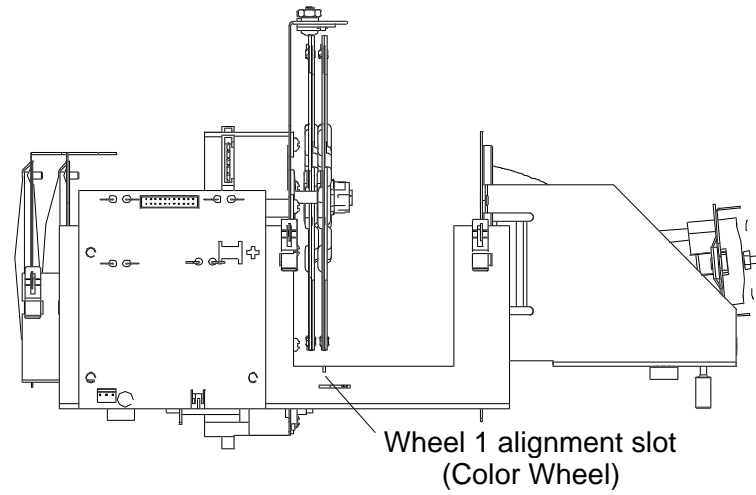
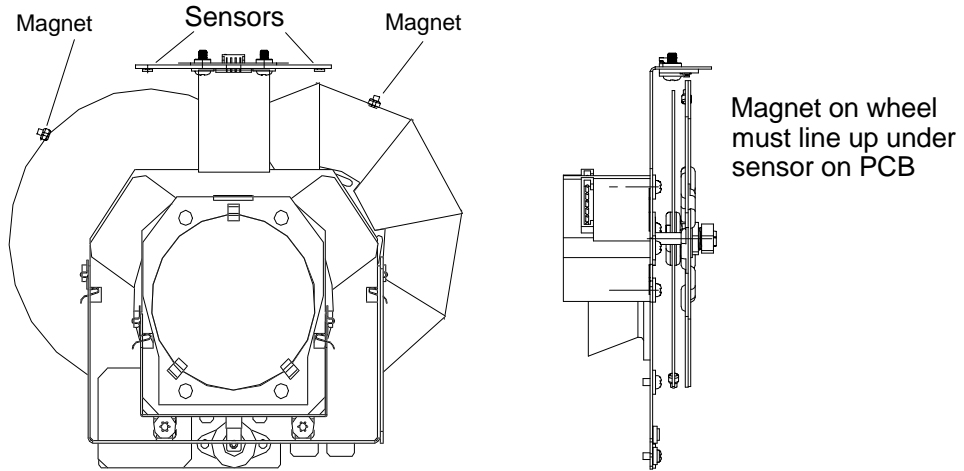

## Lens Removal and Replacement

**WARNING:** Remove power to luminaire at main breaker prior to performing maintenance.

**WARNING:** Wear eye protection during maintenance operations.

The universal lens carriage is equipped with slots to accommodate any one of the wash lens sets, or either of the spot lens configurations. The illustration below shows which slots are used for any given lens configuration.

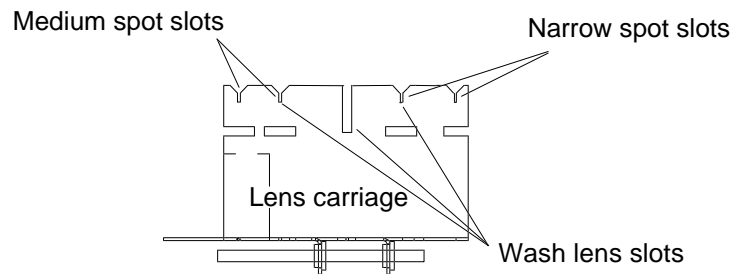

### Spot Luminaire Medium Field-of-View Lens Set

The medium field of view lens set for the spot luminaire is a two lens set. These lenses are small convex lenses. The first element lens is a concavo-convex or meniscus lens (both sides curve away from the light source). The second element lens is a plane convex lens (flat on one side with an outward curve on the other). The curve of this lens also is away from the light source.

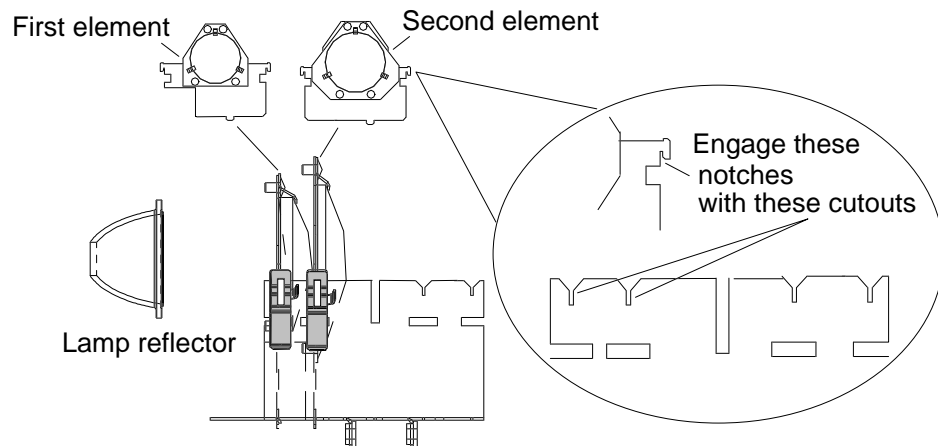

#### To remove and replace a lens:

- Step 1. Remove luminaire trim cover. Refer to **Luminaire Trim Cover Removal and Replacement**.

- Step 2. Lower optical assembly to gain access to lamp. Refer to Steps 1 and 2 of **Optical Assembly Lowering and Removal** procedure.
- Step 3. Remove retaining clips from desired lens.
- Step 4. Grasp metal portion of lens assembly and lift up and away from lens carriage.

Grasp metal portion of lens assembly.  
Pull up and away from lens carriage.

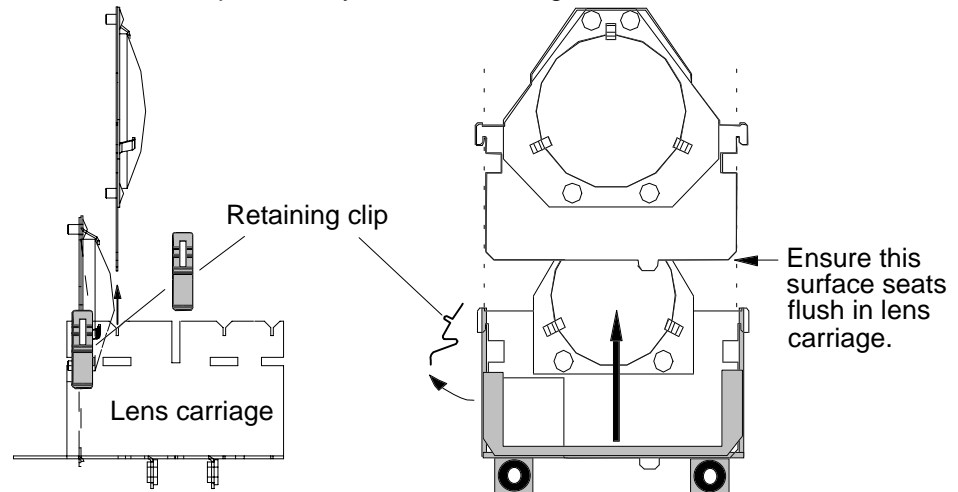

- Step 5. Replace lens by performing Steps 1 through 4 in reverse order.

## Spot Luminaire Narrow Field-of-View Lens Set

The narrow field of view lens set for the spot luminaire is a two lens set. These lenses are convex in type. The first element lens is a single-convex lens (the curve is away from the light source). The second element lens is a bi-convex lens (both sides curved outward). These lenses have a small metal tab located on top of the lens assembly and must be installed with the tab pointing toward light source.

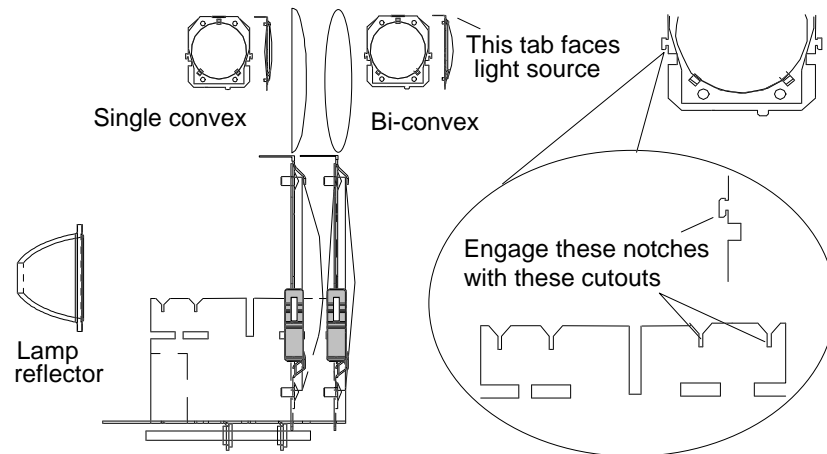

### To remove and replace a lens:

- Step 1. Remove luminaire trim cover. Refer to **Luminaire Trim Cover Removal and Replacement**.
- Step 2. Lower optical assembly to gain access to lamp. Refer to Steps 1 and 2 of **Optical Assembly Lowering and Removal** procedure.
- Step 3. Remove retaining clips from desired lens.
- Step 4. Grasp metal portion of lens assembly and lift up and away from lens carriage.

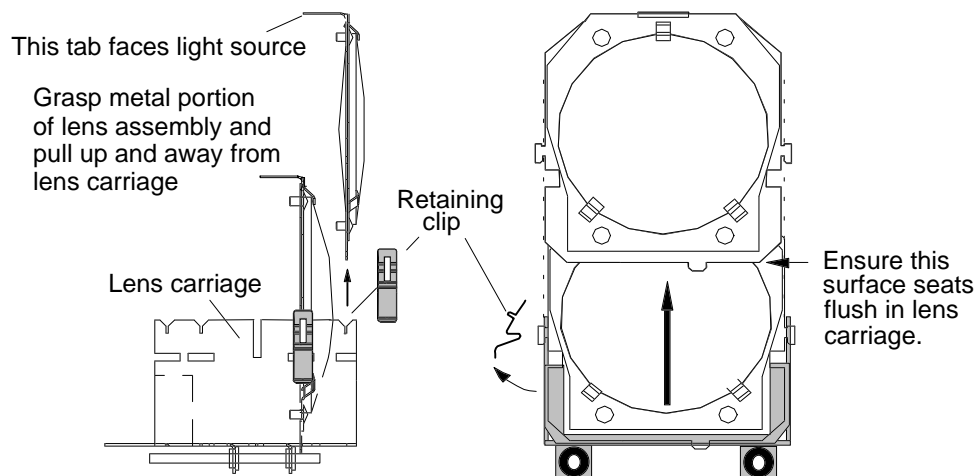

- Step 5. Replace lens by performing Steps 1 through 4 in reverse order.

## Wash Luminaire Lens Set

The lens set for the wash luminaire consists of three lenses. Two glass convex lenses in metal frames and one micro lens with concentric rings to spread the beam and produce the wash effect. To change the wash beam size from narrow to medium to wide field of view, only the micro lens need be changed. The bi-convex lens in front of the wash micro lens has a rear facing metal tab that holds the wash lens in place. The bi-convex lens must first be removed before the wash micro lens can be exchanged.

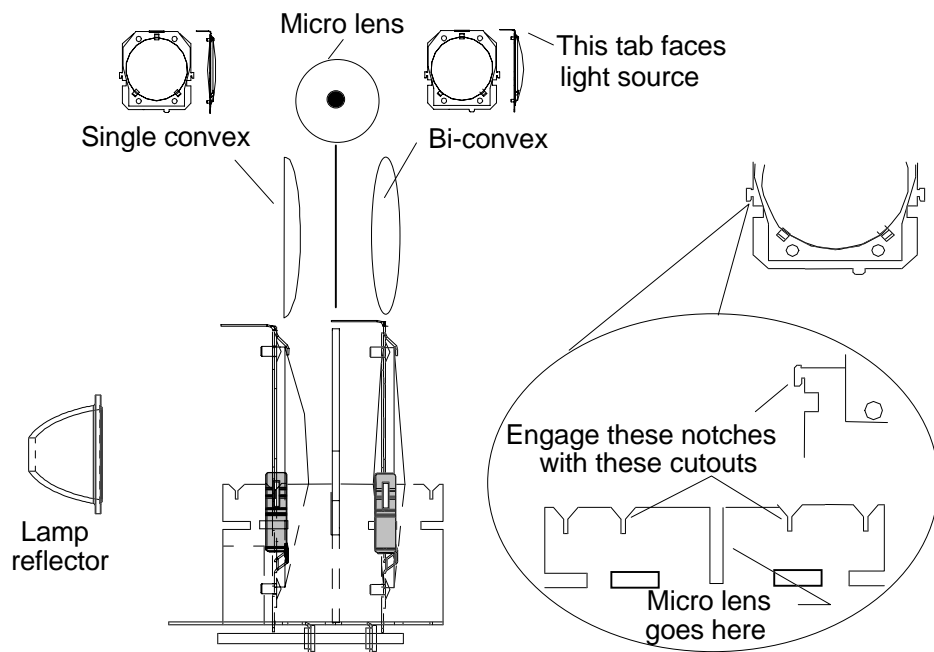

### To remove and replace lenses in the wash luminaire:

- Step 1. Remove luminaire trim cover. Refer to **Luminaire Trim Cover Removal and Replacement**.
- Step 2. Lower optical assembly to gain access to lamp. Refer to Steps 1 and 2 of **Optical Assembly Lowering and Removal** procedure.
- Step 3. Remove retaining clips from desired lens.
- Step 4. Grasp metal portion of lens assembly and lift up and away from lens carriage.
- Step 5. If required, grasp wash micro lens and slide up and out from lens carriage.

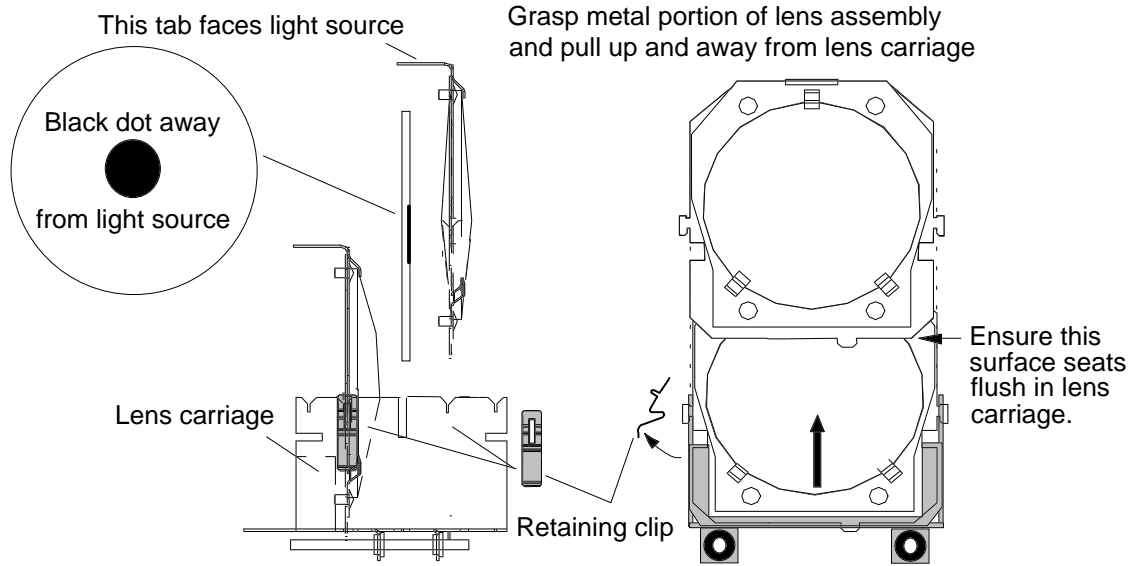

Step 6. Replace lens by performing Steps 1 through 5 in reverse order.