



# ETC Installation Guide

## ColorSource™ PAR

### Overview

The ColorSource PAR is an affordable LED wash fixture that uses the RGB-L (red, green, blue, and lime) color system to provide a rich, bright light.

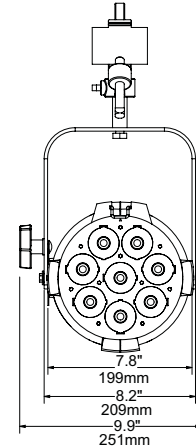
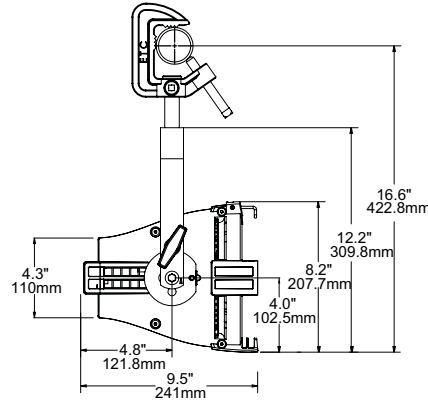
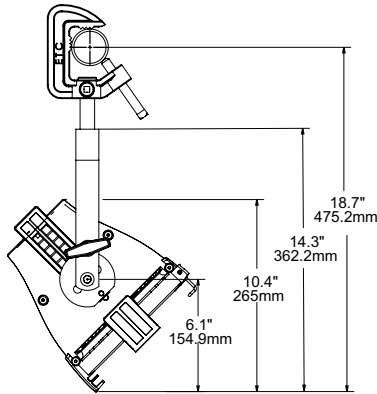

#### CAUTION:

- Risk of eye injury. Do not stare directly into the light.
- Do not operate in proximity to flammable materials.

### Environment

The ColorSource PAR operates in ambient temperatures of 0°- 40°C and it comes with a variable-speed fan.



#### Note:

*The ColorSource PAR is for indoor use only.*

### Electrical



#### WARNING:

**Disconnect the fixture from power and DMX and allow it to cool before performing any cleaning and maintenance.**

- Operates between 100V and 240VAC at a frequency of 50/60Hz.
- Up to 9 luminaires (15A max) may be linked via power thru connector (10 luminaires total per circuit) when used with an R20 relay module or Unison Echo Relay Panel. Consult breaker trip curves when used with other equipment. Requires power from a non-dimmable source.

### Installation

#### Mounting hardware

The ColorSource PAR ships with a standard yoke. An expandable floor stand yoke is available as an optional accessory. Contact your local dealer for more information.

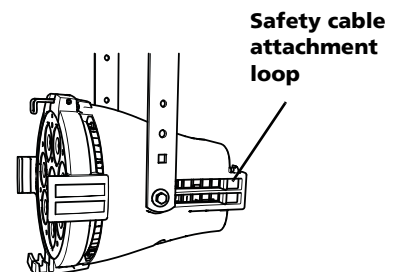

Corporate Headquarters ■ Middleton, WI, USA ■ Tel +608 831 4116 ■ Service: (Americas) [service@etconnect.com](mailto:service@etconnect.com)  
 London, UK ■ Tel +44 (0)20 8896 1000 ■ Service: (UK) [service@etceurope.com](mailto:service@etceurope.com)  
 Rome, IT ■ Tel +39 (06) 32 111 683 ■ Service: (UK) [service@etceurope.com](mailto:service@etceurope.com)  
 Holzkirchen, DE ■ Tel +49 (80 24) 47 00-0 ■ Service: (DE) [techserv-hoki@etconnect.com](mailto:techserv-hoki@etconnect.com)  
 Hong Kong ■ Tel +852 2799 1220 ■ Service: (Asia) [service@etcasia.com](mailto:service@etcasia.com)  
 Web: [www.etconnect.com](http://www.etconnect.com) ■ © 2015 ETC. All Rights Reserved. ■ Product information and specifications subject to change.  
 7412M2100 ■ Rev C ■ Released 2015-04 ■ ETC intends this document to be provided in its entirety.

# ETC Installation Guide

## ColorSource PAR

### Safety cable

The safety cable (or other approved safety device) must be attached to the fixture. Attachment loops are provided on the fixture housing. Take care to leave as little slack as possible in the safety cable to avoid catching the yoke of the fixture.

### Connectors

- **Power in and thru** - two PowerCON connectors for power in and thru
- **Data in and Thru: DMX512/RDM**
  - two five pin XLR connectors *OR*
  - two RJ45 connectors

Conversion cables are available from ETC. Please call your ETC customer service representative and reference part number W6538 for RJ45 to female XLR, and part number W6539 for RJ45 to male XLR.

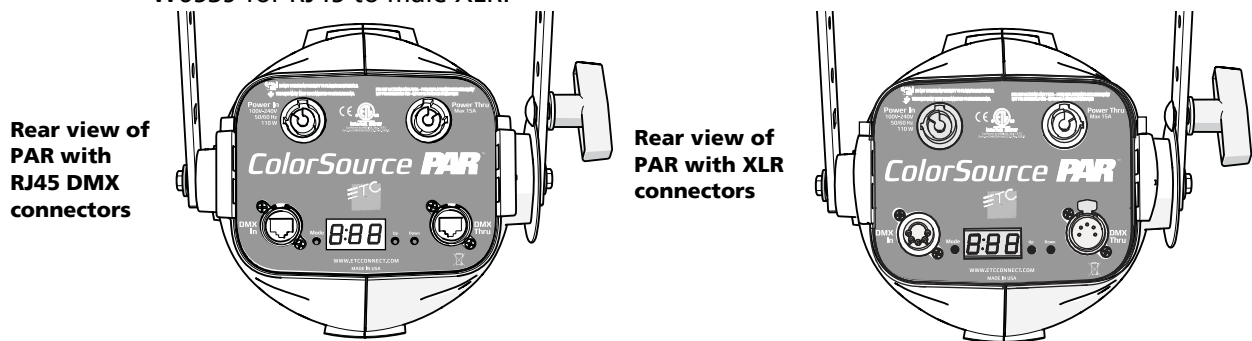

**Note:** *This fixture is not Ethernet/data network compatible.*



**Note:** *The ColorSource PAR is not self terminating. You must terminate the last fixture in line with a 120 ohm resistor. XLR terminators are not available from ETC. To purchase an RJ45 terminator, please contact your ETC customer service representative and request part number N4086.*

### Fixture setup

- Step 1: Plug power cord into the PowerCON in connector on the rear of the fixture.
- Step 2: Make any power-thru cable connections prior to applying a power source.
- Step 3: Plug power cord into power source.

### Power up

- Step 1: Press the Mode button once to wake the display. The first screen you see displays the DMX address.
- Step 2: Press the Mode button a second time to access the Presets/Sequences screen.

### Adjusting the tilt

The fixture can be tilted up and down and rotated (panned) as needed.

- Step 1: Loosen, but **do not remove** the yoke locking knob.
- Step 2: Tilt the fixture to the desired angle.
- Step 3: Tighten the yoke locking knob.

### User interface

The user interface allows you to set the start address of the fixture, and access the stand-alone presets and sequences.

# ETC Installation Guide

## ColorSource PAR

- The DMX address will blink when no DMX is present and a preset or sequence is not active. The inactivity time-out is disabled while in a data loss state.
- After five seconds of inactivity when DMX is present, the display goes dark.

### Mode button

Pressing the Mode button activates the Preset/Sequence selection screen; the last active preset or sequence plays automatically. Pressing the Mode button a second time, deactivates the selected preset or sequence. The display will revert to show the DMX start address.

- If DMX data is present, the current preset or sequence plays in the background and DMX data continues to take priority.
- If DMX data is lost and a preset is active in the background, the last selected preset or sequences automatically plays.

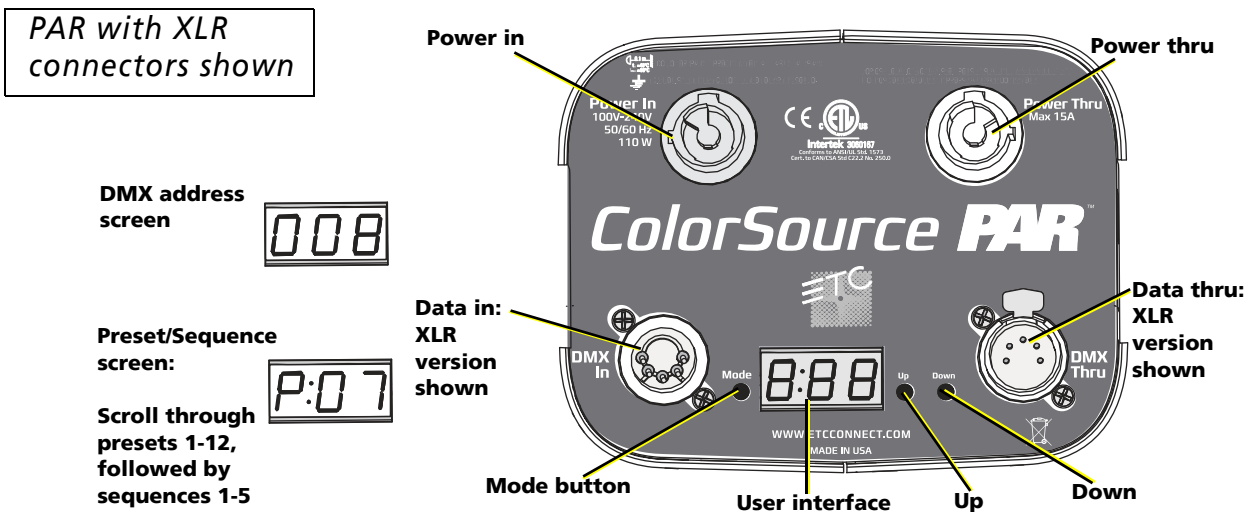

### DMX addressing

- Step 1: Press the Mode button until the DMX address is displayed.
- Step 2: Use the Up and Down buttons to select the DMX address for the fixture.

### Preset and sequence selection

There are twelve factory-configured presets followed by five factory-configured sequences built into the fixture. From the Preset and Sequences menu, use the Up and Down buttons to scroll through the list. The sequence or preset plays immediately upon selection. All presets and sequences can be re-recorded through an RDM device.

To re-record presets:

- Step 1: Using DMX or RDM, set the desired RGB levels.
- Step 2: Navigate to the Preset and Sequences menu.
- Step 3: Using the Up and Down buttons on the PAR, navigate to the preset number you want to re-record.
- Step 4: Hold the Mode button for three seconds to confirm the preset selection. The user interface will show a three second count-down. The preset number will then blink once to confirm the preset has been recorded.

It is possible to activate a known preset or sequence from a connected fixture, when DMX is not present. If a connected fixture activates a preset or sequence that is not recognized by the PAR, the PAR will hold its last look. When DMX is restored, it will take priority.

# ETC Installation Guide

## ColorSource PAR

### Pre-configured presets

Preset	Name	Preset	Name
1	3200K White	7	Magenta
2	5600K White	8	Yellow
3	Red	9	Orange
4	Green	10	Light Yellow
5	Blue	11	Light Blue
6	Cyan	12	Light Pink

### Pre-configured sequences

Sequence	Name
1	Rainbow Fast
2	Rainbow Slow
3	Warm Colors Fast
4	Cool Colors Fast
5	Random

## Power Consumption

	100V	120V	230V
Idle Power / Current	1.22W/0.026A	1.21W/0.026A	1.14W/0.026A
100% RGB Regulated Power / Current	90.8W/0.909A	89.7W/0.75A	88.7W/0.4A

## DMX Control Channels

DMX Profile	Description
1	Intensity
2	Red
3	Green
4	Blue
5	Strobe



**Note:** *The fixture listens to RGB but interprets color output using the full RGB-L array. It is not possible to control a single group of LEDs; i.e. only blue.*

## Error codes

There are three error codes that may be shown on the user interface.

- **CAL:** Indicates a problem with the color calibration. The fixture will need to be returned to the ETC factory; contact your local dealer to setup a repair.
- **OtP:** Indicates that the fixture has gone into over-temperature protection mode to avoid damaging the fixture. Once the fixture has self-cooled, the error will automatically clear.
- **NoApp:** Indicates that upgraded fixtures have a software issue. Reload software to clear the error. If the error persists, contact ETC.

## To restore factory defaults:

Hold all three buttons down simultaneously for five seconds. You will see the DMX start address blink once to confirm that defaults have been restored.