

# ETC Installation Manual



## ColorSource® Spot

### Overview

The ColorSource Spot is an affordable profile fixture that offers the quality and support of an ETC LED fixture. Utilizing an RGB-L color mixing system, the ColorSource Spot produces amazing color and output for a four-color fixture. This light engine can be used with standard ETC shutter barrels, lens tubes, Fresnel and Cyc Adapters, and accessories.



- CAUTION:**
- Risk of eye injury. Do not stare directly into the light.
  - Do not operate in proximity to flammable materials.

### Environment

The ColorSource Spot operates in ambient temperatures of 0°- 40°C and comes with a variable-speed, quiet operation fan.



**Note:** *The ColorSource Spot is for use in dry locations only.*



- Note:**
- Maximum recommended ambient operating temperature: Ta = 40°C (104°F)
  - Maximum anticipated external surface temperature at 40° ambient: Tmax = 80°C (176°F)
  - External temperatures after 5 minutes of full-brightness operation at 25°C (77°F) ambient: 30°C (86°F)
  - External Temperature (steady state achieved) at 25°C (77°F): 36°C (97°F)

### Electrical



**WARNING:** **Disconnect the fixture from power and DMX and allow it to cool before performing any cleaning and maintenance.**

- Operates between 100V and 240VAC at a frequency of 50/60Hz.
- Up to 9 luminaires (15A max) may be linked via power thru connector (10 luminaires total per circuit) when used with an R20 relay module or Unison Echo Relay Panel. Consult breaker trip curves when used with other equipment. Requires power from a non-dimmable source.

### Installing a shutter barrel

The ColorSource Spot can be purchased with or without a shutter barrel. To install a shutter barrel you will need a #2 Phillips Screwdriver. (not provided)

The ColorSource light engine includes a barrel screw. The small screw used to secure the top of the shutter barrel is included with the shutter barrel.

- Step 1: Align the barrel to the front of the ColorSource Spot and rotate it one quarter turn counter-clockwise
- Step 2: Insert the shutter barrel into the front of the light engine and rotate clockwise until it is fully threaded onto the light engine.

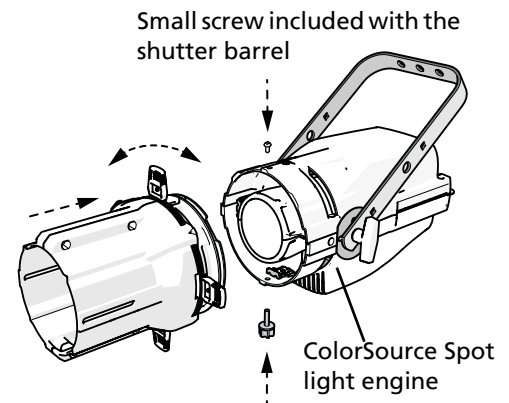

**Corporate Headquarters** ■ Middleton, WI, USA ■ Tel +608 831 4116 ■ Service: (Americas) [service@etconnect.com](mailto:service@etconnect.com)  
**London, UK** ■ Tel +44 (0)20 8896 1000 ■ Service: (UK) [service@etceurope.com](mailto:service@etceurope.com)  
**Rome, IT** ■ Tel +39 (06) 32 111 683 ■ Service: (UK) [service@etceurope.com](mailto:service@etceurope.com)  
**Holzkirchen, DE** ■ Tel +49 (80 24) 47 00-0 ■ Service: (DE) [techserv-hoki@etconnect.com](mailto:techserv-hoki@etconnect.com)  
**Hong Kong** ■ Tel +852 2799 1220 ■ Service: (Asia) [service@etcasia.com](mailto:service@etcasia.com)  
**Web:** [www.etconnect.com](http://www.etconnect.com) ■ © 2015 ETC. All Rights Reserved. ■ Product information and specifications subject to change.  
7413M2100 ■ Rev A ■ Released 2015-05 ■ ETC intends this document to be provided in its entirety.

# ETC Installation Manual

## ColorSource Spot

---

- Step 3: Insert the barrel screw at the bottom of the light engine and tighten.
- Step 4: Insert the small screw into the top of the light engine and tighten using the Phillips screwdriver

### Mounting hardware

- The ColorSource Spot ships with a standard yoke for mounting with a c-clamp.
- The provided safety cable (or other approved safety device) must be attached to the fixture. Two attachment loops are provided on the rear of the fixture body. Take care to leave as little slack as possible in the safety cable to avoid catching the yoke of the fixture.

### Connectors

- **Power Connectors** - two PowerCON connectors for power in and thru
- **Data in and Thru: DMX512/RDM** -
  - two five pin XLR connectors OR
  - two RJ45 connectors



---

**Note:** *This fixture is not Ethernet/data network compatible.*

---



---

**Note:** *The ColorSource Spot is not self terminating. You must terminate the last fixture in line with a 120 ohm resistor. XLR terminators are not available from ETC. To purchase an RJ45 terminator, please contact your ETC customer service representative and request part number N4086.*

---

### Fixture setup

- Step 1: Plug power cord into the PowerCON in connector on the rear of the fixture.
- Step 2: Make any power-thru cable connections prior to applying a power source.
- Step 3: Plug power cord into power source.

### Power up

- Step 1: Press the Mode button once to wake the display. The first screen you see displays the DMX address.
- Step 2: Press the Mode button a second time to access the Presets/Sequences screen.

### Adjusting the tilt

The fixture can be tilted up and down and rotated (panned) as needed.

- Step 1: Loosen, but **do not remove** the yoke locking knobs.
- Step 2: Tilt the fixture to the desired angle.
- Step 3: Tighten the yoke locking knobs.

### User interface

The user interface allows you to set the start address of the fixture, and access the stand-alone presets and sequences. After five seconds of inactivity, the display goes dark

#### User interface lock

**To lock:** Press and hold the up and down arrows for three seconds to lock the user interface. The UI will show "Loc" when locked.

**To unlock:** Press and hold the up and down arrows for three seconds to unlock the user interface.

# ETC Installation Manual

## ColorSource Spot

### Mode button

Pressing the Mode button activates the Preset/Sequence selection screen; the last active preset or sequence plays automatically. Pressing the Mode button a second time, deactivates the selected preset or sequence. The display will revert to show the DMX start address.

- If DMX data is present, the current preset or sequence plays in the background and DMX data continues to take priority.
- If DMX data is lost and a preset is active in the background, the last selected preset or sequences automatically plays.

### DMX addressing

Step 1: Press the Mode button until the DMX address is displayed.

Step 2: Use the Up and Down buttons to select the DMX address for the fixture.

Spot with XLR connectors shown

DMX address screen



Preset/Sequence screen:



Scroll through presets 1-12, followed by sequences 1-5

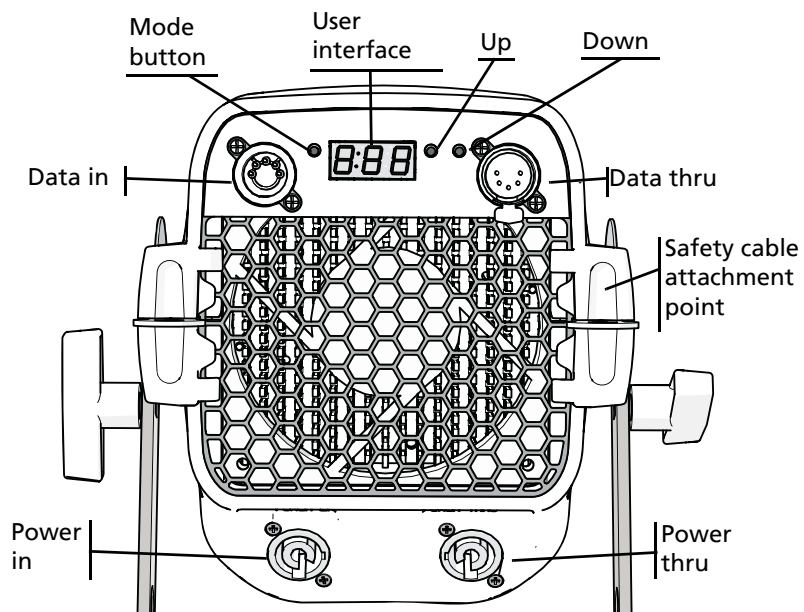

### Preset and sequence selection

There are twelve factory-configured presets followed by five factory-configured sequences built into the fixture. From the Preset and Sequences menu, use the Up and Down buttons to scroll through the list. The sequence or preset plays immediately upon selection. All presets and sequences can be re-recorded through an RDM device.

*To re-record presets:*

- Step 1: Using DMX or RDM, set the desired RGB levels.
- Step 2: Navigate to the Preset and Sequences menu.
- Step 3: Using the Up and Down buttons on the PAR, navigate to the preset number you want to re-record.
- Step 4: Hold the Mode button for three seconds to confirm the preset selection. The user interface will show a three second count-down. The preset number will then blink once to confirm the preset has been recorded.

It is possible to activate a known preset or sequence from a connected fixture, when DMX is not present. If a connected fixture activates a preset or sequence that is not recognized by the Spot, the Spot will hold its last look. When DMX is restored, it will take priority.

# ETC Installation Manual

## ColorSource Spot

### Pre-configured sequences

Preset	Sequence
1	Rainbow Fast
2	Rainbow Slow
3	Warm Colors Fast
4	Cool Colors Fast
5	Random

### Pre-configured presets

Preset	Name	Preset	Name
1	3200K White	7	Magenta
2	5600K White	8	Yellow
3	Red	9	Orange
4	Green	10	Light Yellow
5	Blue	11	Light Blue
6	Cyan	12	Light Pink

## Power Consumption

	100V	120V	240V
Idle Power / Current	1.19W/0.0465A	2.07W/0.0479A	1.5W/0.0531A
100% Boost Power / Current	177W/1.76A	176W/1.46A	171W/0.739A

## DMX Control Channels

DMX Profile	Description
1	Intensity
2	Red
3	Green
4	Blue
5	Strobe



**Note:** *The fixture listens to RGB but interprets color output using the full RGB-L array. It is not possible to control a single group of LEDs; i.e. only blue.*

## Error codes

There are three error codes that may be shown on the user interface.

- **CAL:** Indicates a problem with the color calibration. The fixture will need to be returned to the ETC factory; contact your local dealer to setup a repair.
- **OtP:** Indicates that the fixture has gone into over-temperature protection mode to avoid damaging the fixture. Once the fixture has self-cooled, the error will automatically clear.
- **NoApp:** Indicates that upgraded fixtures have a software issue. Reload software to clear the error. If the error persists, contact ETC.

## To restore factory defaults:

Hold all three buttons on the user interface down simultaneously for five seconds. You will see the DMX start address blink once to confirm that defaults have been restored.